

# SOLPAD

Multifunctional Flood Lights  
10W

## Installation Manual

SOLTECH Provides Advanced LED  
Technology Powered With Eco-friendly,  
Clean, Solar Energy.



**SOLTECH**  
Smart Solar Lighting

# 01 Introduction

Thank you for purchasing SOLPAD Urban Lighting Products.

### Important

Please read these instructions before installation to ensure optimum results and longevity of your lights. The solar panel should be charged in full sunlight for 8 to 9 hours before initial first use to provide optimum results.

### Features

- Solar panel bracket is 360° adjustable and the light module is 135° adjustable. The Adjustable solar panel angle enables maximizing sunlight collected and allows snow to slide off.
- Large battery capacity of 7200mAh enables long run times.
- Wall-mounting and post-mounting accessories available
- The latest advanced Li-ion battery lasts 2000+ charging cycles
- 3 operating modes that are programmable via remote control or controls on the fixture
- IP65 rated protection from water, dirt, and dust.
- The easiest way to bring lighting to any outdoor application
- Photo and motion sensors, wide angle 180° detection, high sensitivity
- Wall-mounting and post-mounting accessories available

### Notice & Warning

1. The SOLPAD will provide optimal usage where there is enough sunshine.
2. Please note the lighting time depends on sunshine duration and weather.
3. The lamp will light up automatically at dusk.
4. Built-in intelligent IC is with over-charge, over-discharge and over-voltage protection.
5. The lamp is equipped with an internal battery pack, which is replaceable. If needed, please contact for correct new battery pack.
6. If the battery is taken out and put back in or replaced with new batteries, please allow the solar panel to receive maximum sunshine to activate the lamp.
7. Non-professionals please do not disassemble the lamp.
8. Please do not dispose the battery with household garbage to avoid explosion.

### Please Note

During continuous rainy or cloudy days, run time may be reduced as the battery will not be fully charged.

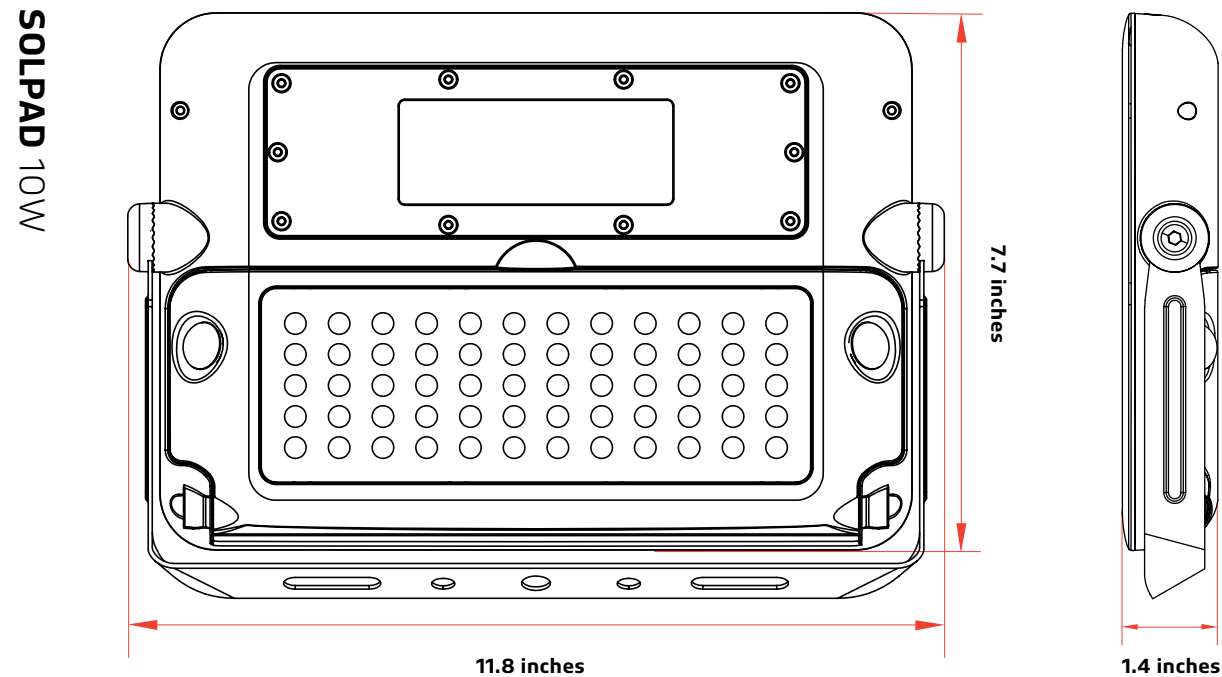

# 02 Specification

Specifications	SOLPAD 10W
LED Nominal Power	10W
Solar Panel	Mono-Crystalline 5.5V 6W
Lithium Ion Battery	27WH 3.7V 7.2AH
CCT	4,000K & 5,000K
Lumen Output@4000K	1,000
CRI	> 70
Product Size	11.8 X 7.7 X 1.4 Inches
Beam Angle	90°
Light Panel & Bracket	Light Panel: 135° Adjustable Bracket: 360° Adjustable
Waterproof Rate	IP65
Casting	PC & Aluminum
Efficiency@4000K	100 lm/W
*Charging Time	7hrs (1000W/m <sup>2</sup> )
Run Time (@Full Power)	2-3 Days
Operation Mode	3 Operating Modes
PIR Sensor Angle / Distance	180° / 16-26 ft
*Operating Temperature	-5 °F to 113 °F
*Charging Temperature	32 °F to 149°F

### Ordering Information Chart

SERIES	WATTAGE	COLOR TEMPERATURE	MOUNTING OPTIONS	FINISH
STL-SFL=SOLPAD	10=10W 1000 Lumens	4=4000K 5=5000K	WM=Wall Mount LP=LAMP-POST MOUNT	BK=BLACK

-  -  -  -

\* The temperature can impact the battery's charging and normal operation.

\* The solar charge time data is base on 77 degree F ambient temperature with the panel pointed directly at the solar radiation. The standard radiation value is 1000W/m<sup>2</sup>.

# 03 Installation

## WALL MOUNT

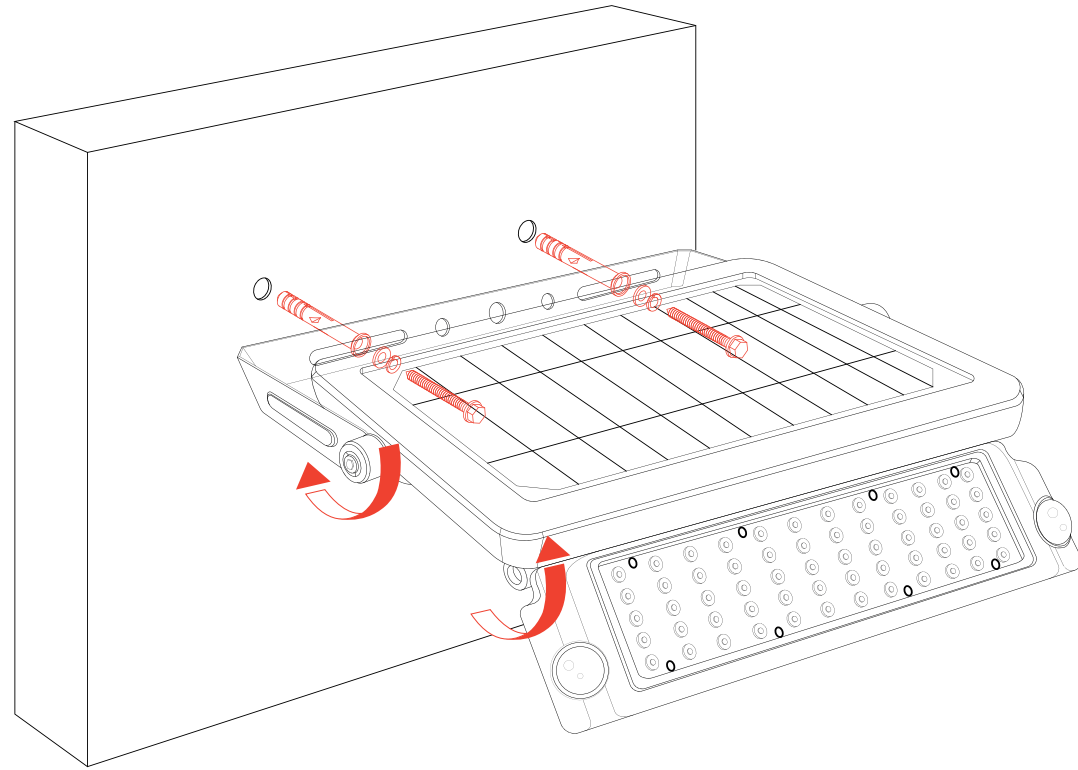

1. Use the Allen Wrench to loosen the bracket. Adjust it to the appropriate angle and tighten screws.
2. Use the Allen Wrench to loosen the light module. Pull it out and adjust it to your desired lighting angle, then tighten screws.
3. Mount the light onto the wall.

## LAMP-POST MOUNT

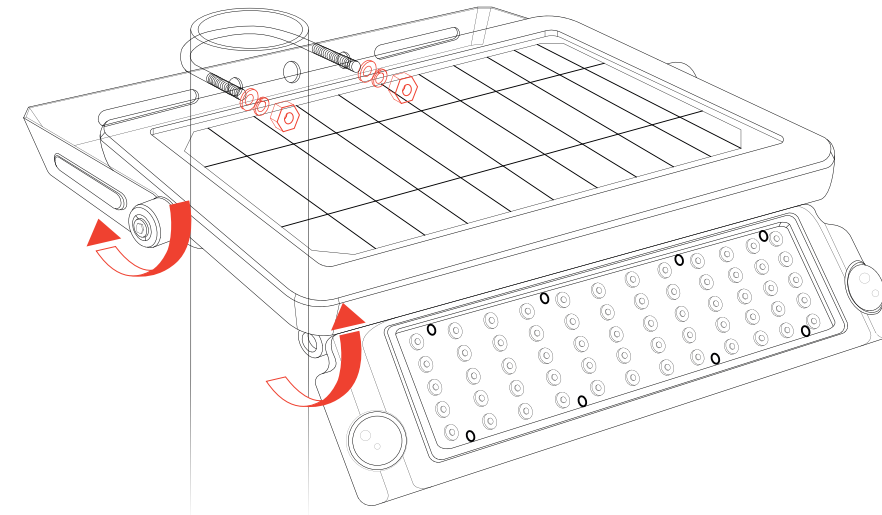

### Works With Round & Square Poles

1. Round Pole Mount  
Diameter of 1.6-2.4 inches
2. Square Pole Mount  
Side length of 1.2-1.6 inches

# 04 Remote Control

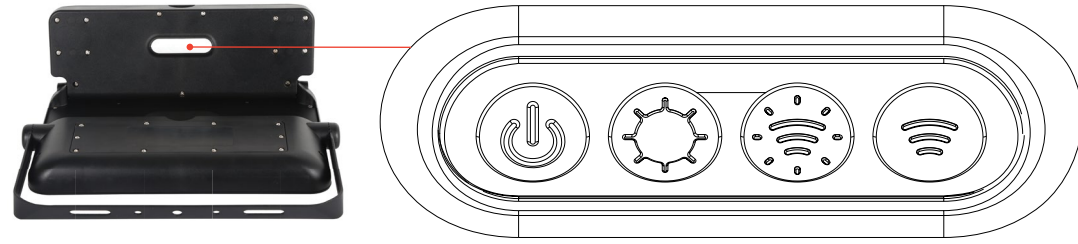

Please press any button to specific operating mode, 6 hours of sunlight can provide operation for 3-4 nights.



**1. On / Off**



**2. Constant Lighting Mode**

Automatically turns on at dusk and remains at 20% brightness

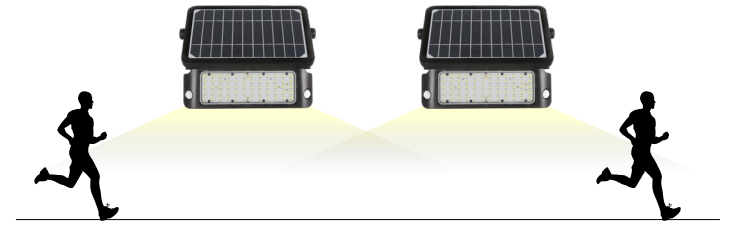

**3. Full Bright & Dim**

Automatically turns on to full brightness (1000 lm) when motion is detected within a range of  $\leq 26$  ft and then reduces to 3% brightness in 20 seconds of no motion.



**4. Full Bright & Off**

Automatically turns on to full brightness (1000 lm) when motion is detected within a range of  $\leq 26$  ft and then turns off after 30 seconds of no motion.

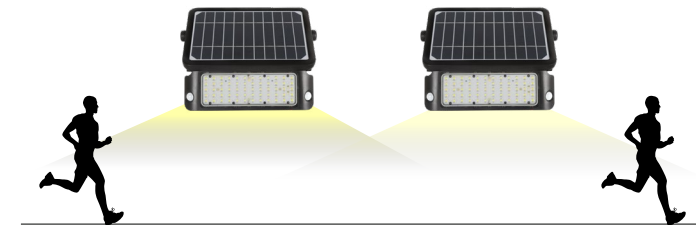

# 05 Panel Angle

The solar charge in a battery pack won't last forever. The off-grid system relies on stored solar energy for autonomy. Angling your solar panels properly can boost the power intake of your solar lighting system. You want to angle your solar panels at a tilt based on the area's latitude.

## Tip

You can increase the tilt 15° in the winter or decrease 15° in the summer. In this way you can get the maximum sunlight to recharge the battery.

## Key



## Best Facing Direction of Solar Panel

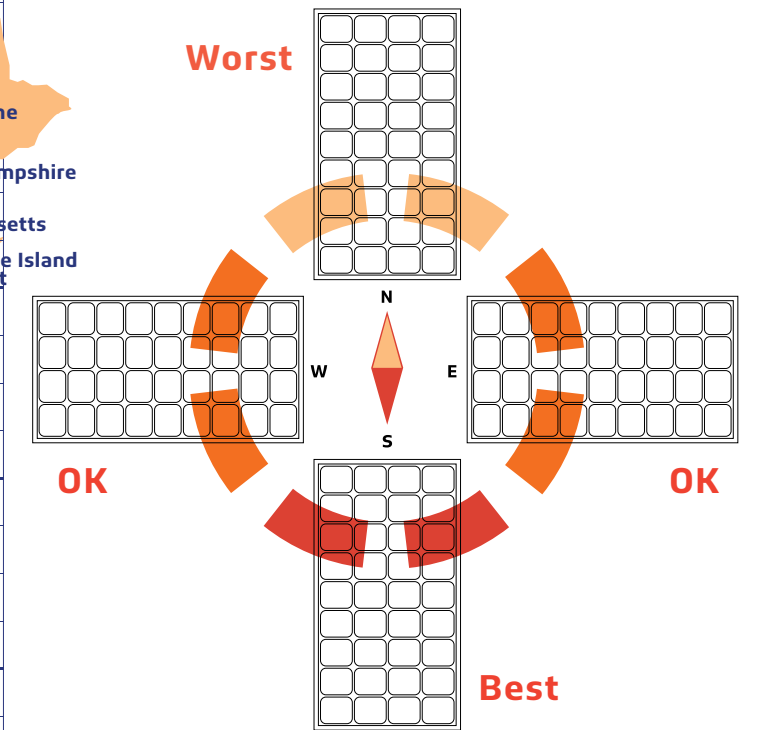

The area will dictate the installation of the fixtures and will sometimes prevent the lights from facing south. But that's okay! Panels facing West & East won't get as much light as Southern facing panels, but will still collect a good amount of sunlight. A North facing panel also works, but it will take longer to charge than any other direction. This would mean that the solar charge will be less optimal if installations are facing North.



**Alaska**

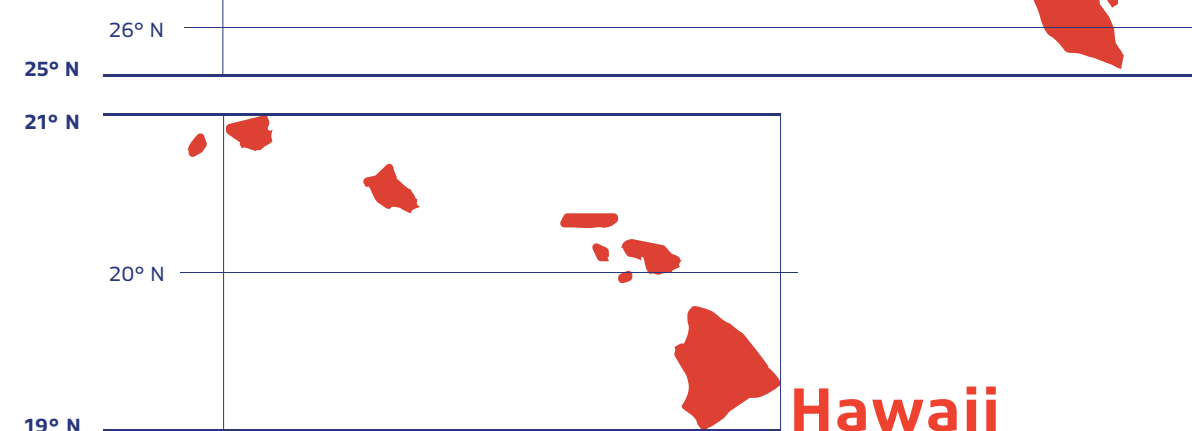
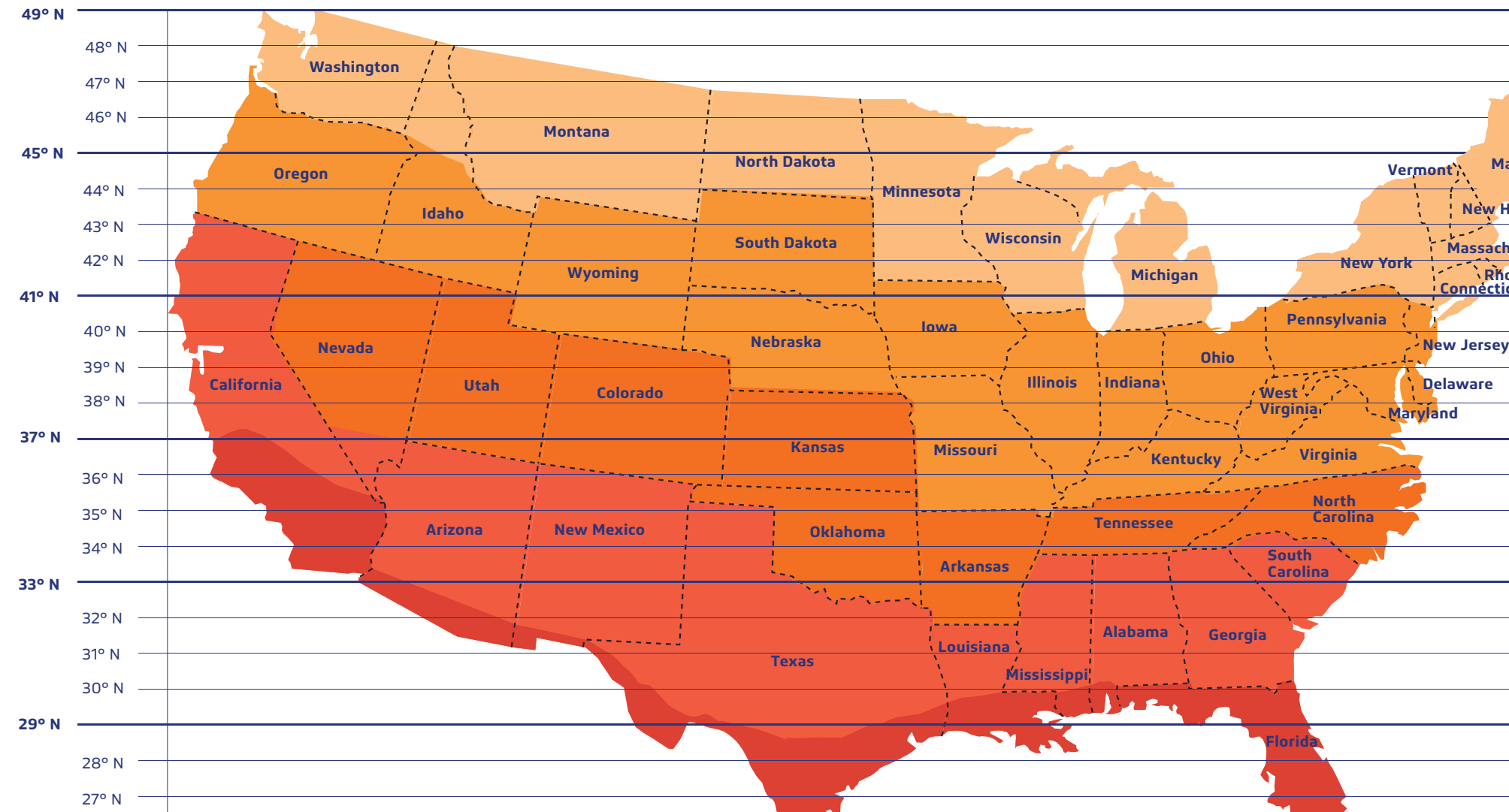

**Hawaii**

## World Wide Panel Angles

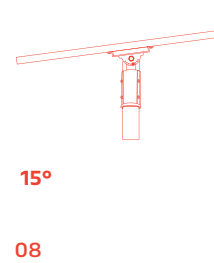
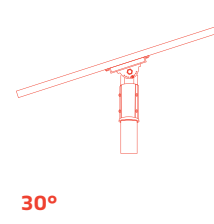
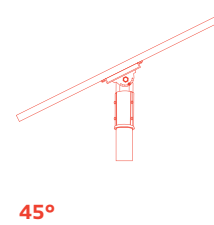
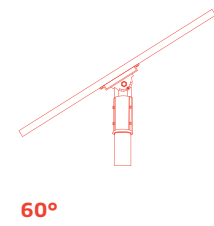
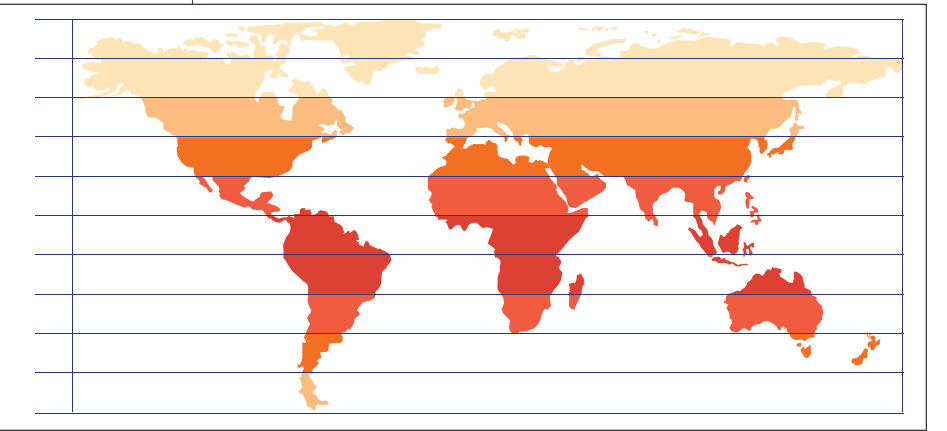
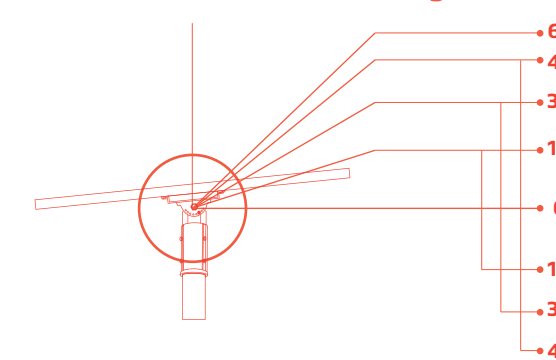

## 06 Luminous Distribution

### SOLPAD 10W

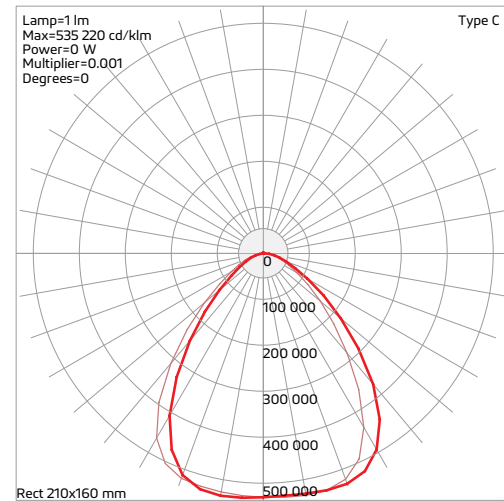

## 07 Warranty

SOLPAD is covered by a 3 year limited warranty. SOLTECH urban light warrants to the original purchaser that this product is free from defects in materials and workmanship for the period of 3 years from date of purchase. To obtain warranty service please contact your local distributor or sales rep for further instruction.

**SOLTECH Provides  
Advanced LED  
Technology Powered  
With Eco-friendly,  
Clean, Solar Energy.**



1460 Park Avenue.  
Emeryville, CA 94608 USA  
[www.soltechlighting.com](http://www.soltechlighting.com)

*SOLTECH LLC reserves the right to update all product data sheets at any time. Consult SOLTECH marketing specialists for publication updates at [hello@soltechlighting.com](mailto:hello@soltechlighting.com)*

*Copyright©2021–2022 SOLTECH LLC,  
All Rights Reserved.*