



TWINKO

MOBILE SOLAR LIGHT TOWER Installation Manual

Ideal for Construction, Natural Disasters,
and Other Temporary Lighting Needs.



TWINKO
MOBILE SOLAR
LIGHT TOWER

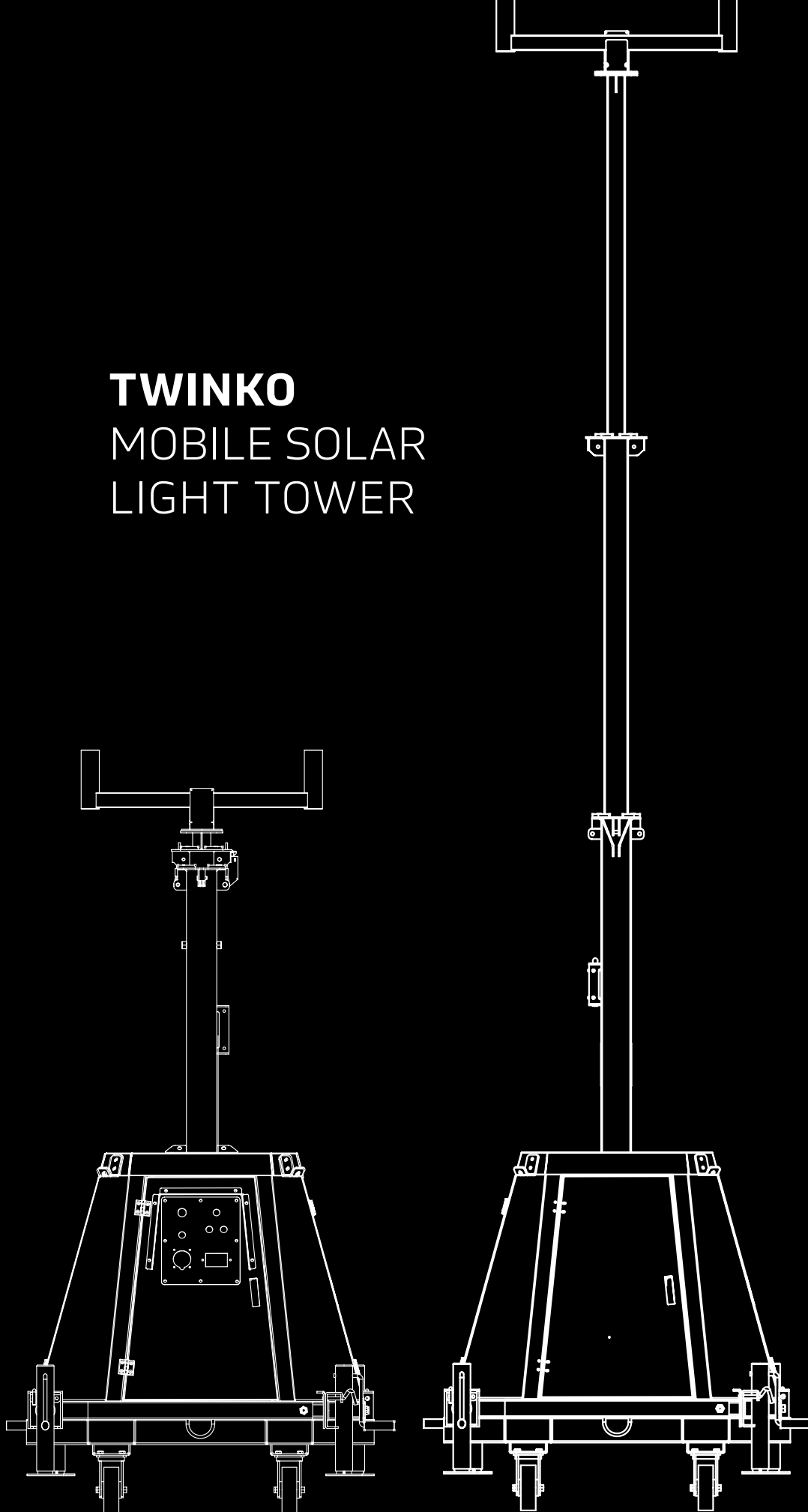

Contents

01 Introduction	04
02 Specifications	06
03 Installation and Wiring Requirements	08
04 Ordering Information	09
05 Installation	010
06 Panel Angle	012
07 Remote Control Guide	014

01 Introduction

Thank you for purchasing the TWINKO mobile solar light tower.

Introduction

Outdoor solar lighting systems use solar cells which convert sunlight into electricity. Electricity is stored in batteries for use at night. TWINKO Mobile Solar Light Tower combined with SUNLIKE solar lights are easy to install and virtually maintenance free. Using them avoids trenching, cabling, and electricity costs.

Important

In order to avoid deep discharge of the battery during storage, please fully recharge your battery every 4 months. Please make sure that the light is installed in an area with sufficient sunlight. A strict minimum of 3.5 hours/day of sunshine on average is recommended. Select the right operating mode according to local codes and solar conditions. Keep it away from shadows. Self-cleaning occurs when the light fixture has minimum angle of 15 degrees above horizontal.

Please save these instructions. Read all of the instructions carefully before attempting to carry out any installation or wiring. Do not open or attempt to repair a SOLTECH luminaire on your own, as it may cause serious damage and would void the product warranty. Contact your local distributor for any questions concerning the installation.

Range of the lighting fixtures is 20–26 feet (6–8 meters). The ideal installation spacing between fixtures is <16 feet (5 meters). When installing two or more light fixtures on one pole, select desired operating mode before installation. Radio frequency interference can cause delay or malfunction of the remote control when changing operating modes, after installation.

Precautions when working with solar panels

When the solar panel is exposed to sunlight, a voltage appears at the output terminals of the solar panel, turning it into a source of electricity. To avoid a shock hazard, make sure the solar panel is covered with an opaque (dark) covering, such as paper or cloth, during the installation. Do not make contact with the terminals when the panel is exposed to sunlight or any other light source.

Luminaire Options

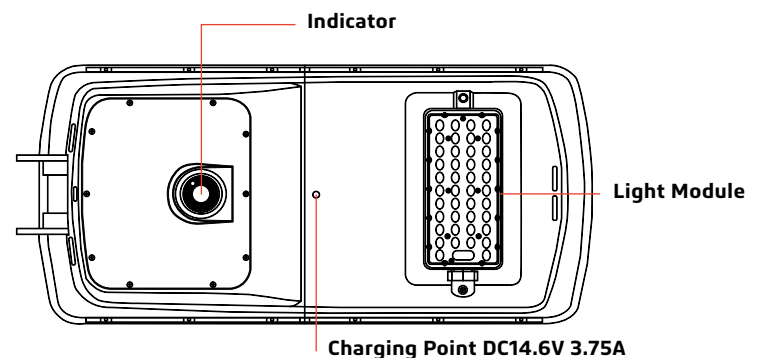
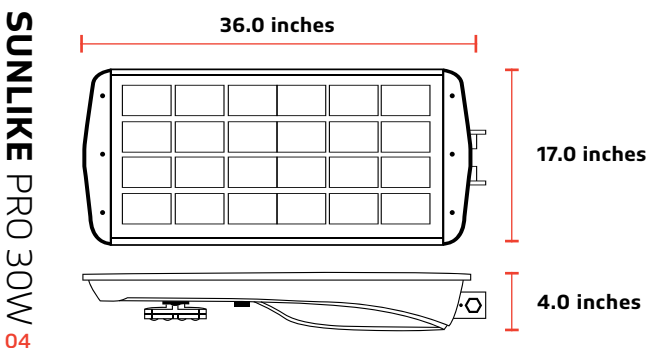
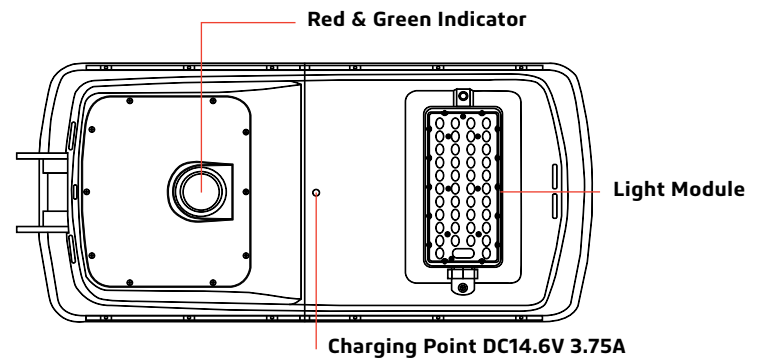
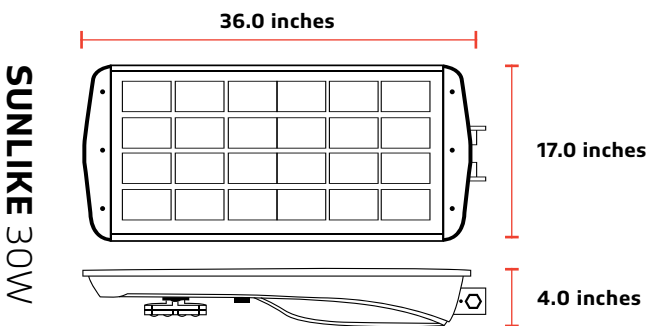
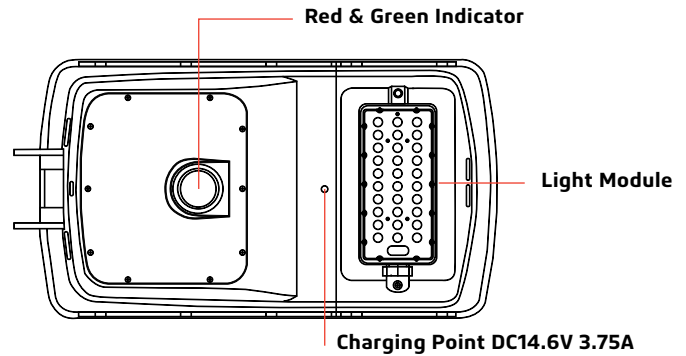
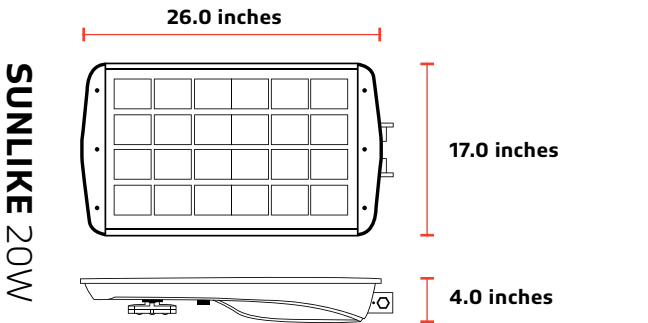

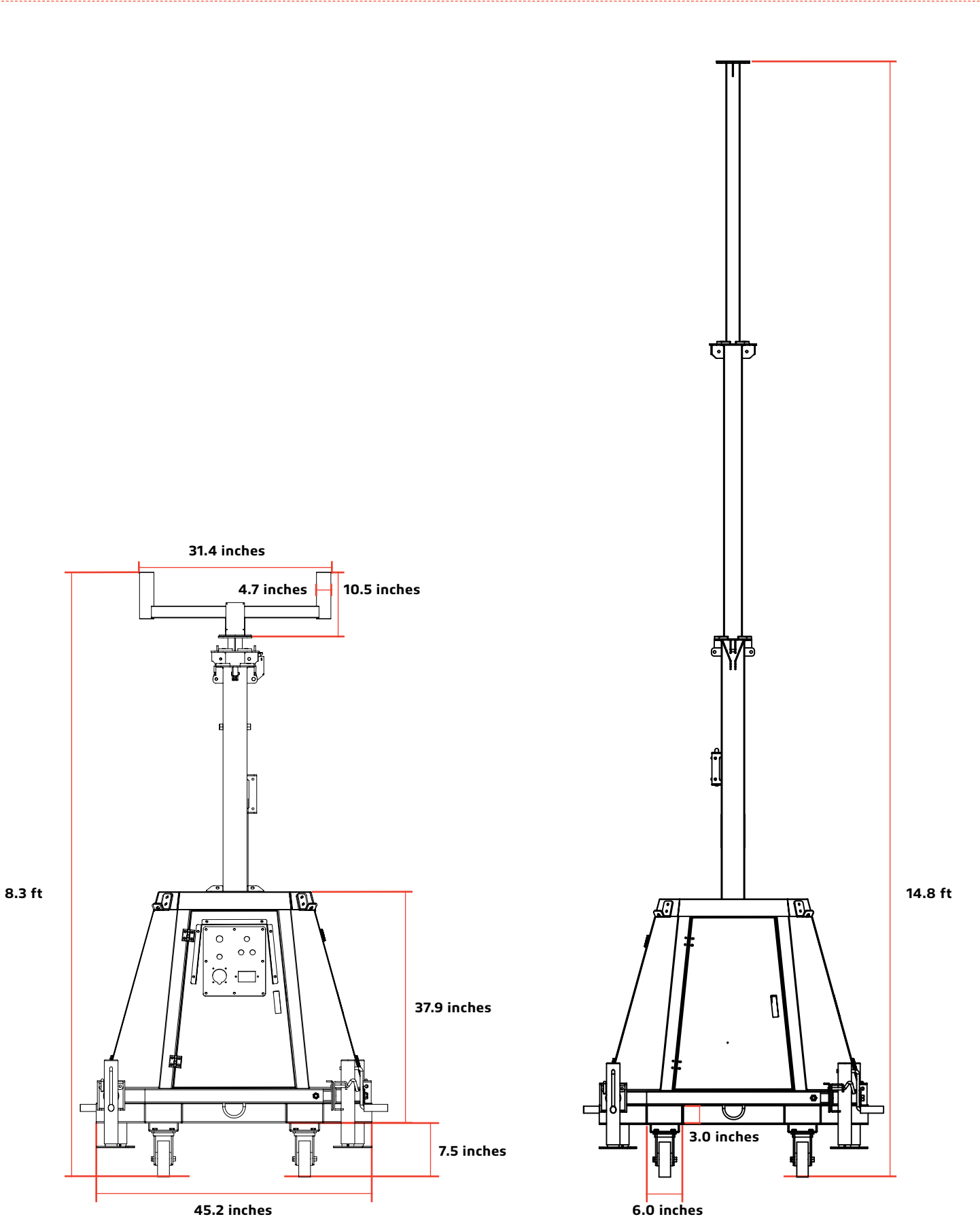

02 Specifications

Specifications	TWINKO
Max Height	14.8 ft (Without Luminaire)
Collapsed Height	8.3 ft (Without Luminaire)
Mast Material	Steel
Mast Profile	Square
Mast Sections	3
Operation	Electric Winch 3000 Lbs, DC12V
Battery	GEL DC12V 150AH, 120 times Lift and Down Autonomy
Charger	1,500W AC 110V Input
Mast Max Load	88 Lbs
Max Wind Speed	90 mph
Warning Strips	Included
Lift Limit Stopper	Included
Lifting Eyes	X4
Fork Pockets	Included
Wheel	Included (With Brake)
Mast Flange	Included
Weight	1,210 Lbs (Without Luminaire)
Dimensions	45.2 inches X 45.2 inches X 99.6 inches (Collapsed Without Luminaire)

Luminaire Specifications	SUNLIKE 20W	SUNLIKE 30W	SUNLIKE PRO 30W
LED Nominal Power	20W	30W	30W
Solar Panel	18V 36W	18V 52W	18V 52W
Battery	256WH 12.8V 20AH LiFePO ₄	384WH 12.8V 30AH LiFePO ₄	320 WH 12.8V 25AH Superior
Weight	21.4 lbs	29.8 lbs	47.1 lbs
Lumen Output@5000K	4,000	6,000	6,000
CRI	> 70	> 70	> 70
LED Chip	Lumileds 5050 (215lm-CR>70)	Lumileds 5050 (215lm-CR>70)	Lumileds 5050 (215lm-CR>70)
EPA	4.75	6.26	6.26
Waterproof Rating	IP65	IP65	IP65
Casting	Aluminum	Aluminum	Aluminum
Efficiency@5000K	200 lm/W	200 lm/W	200 lm/W
* Charging Time	7hrs	7hrs	7hrs
Run Time(@Full Power)	10hrs	10hrs	11hrs
Operation Mode	Remote control and One-key Setting	Remote control and One-key Setting	Remote control and One-key Setting
Installation Height	9 to 16ft	9 to 20ft	9 to 20ft
* Operating Temperature	-4 °F to 122 °F	-4 °F to 122 °F	-4 °F to 140 °F
* Charging Temperature	32 °F to 149 °F	32 °F to 149 °F	-58 °F to 140 °F
Maximum Autonomy			
Motion Sensor Mode	40%-100% 35hrs 20%-80% 55hrs	40%-100% 35hrs 20%-80% 55hrs	40%-100% 25hrs 20%-80% 50hrs
Time Control Mode	Night Owl 28hrs Early Bird 25hrs	Night Owl 28hrs Early Bird 25hrs	Night Owl 23hrs Early Bird 20hrs
Constant Mode	100% 11hrs 70% 15.5hrs 40% 27hrs	100% 11hrs 70% 15.5hrs 40% 27hrs	100% 11hrs 70% 15hrs 40% 26hrs

* The temperature can impact the battery's charging and normal operation. If your place's temperature is under 32°F, we advice you to use the SUNLIKE PRO version to achieve better lighting results. * The solar charge time data is base on 77 degree F ambient temperature with the panel pointed directly at the solar radiation. The standard radiation value is 1000W/m².

03 Installation and Wiring Requirements

1. Installation and wiring must comply with the State and National Electrical Codes.
2. The SUNLIKE 20W/30W/30W PRO models are intended for outdoor use only and should not be installed in an unventilated area, and must be installed in an environment within the operating temperatures defined for the product.
3. The average sunshine in the installation area should be above 3.5 hours/day in order to ensure full function of the light fixture. Avoid areas with shade.
4. Before installation, if applicable, please ensure the light pole and its foundation are stable enough to withstand the lighting fixture(s).
5. Before installation, please ensure that the battery is fully charged. Install during sunny days if possible.
6. Before installation, press the  ON/OFF key on the remote control and check whether it shows a red light on the indicator. Cover the solar panel and check if the light module turns on normally within 1 minute.

After Installation

The light fixture will automatically turn on at night and turn off during daylight.

Important

Always orient the solar panel facing the equator (e.g. facing south if in northern hemisphere).

Always have a tilt angle of at least 15° to avoid dust accumulation (0°=horizontal plane).

04 Ordering Information

Tower	Fixture						
	Series	Wattage	Optic Type	Color Temperature	Mounting Options	Finish	Fixture Qty
STLTWR01E =TWINKO Solar Mobile Tower	STLSTC =SUNLIKE STLSTCPR0 =SUNLIKE PRO	20 =20W 4000 Lumens <small>(only for SUNLIKE)</small> 30 =30W 6000 Lumens	T2 =TYPE II <small>(only for SUNLIKE 30W SUNLIKE PRO 30W)</small> T3 =TYPE III T4 =TYPE IV <small>(only for SUNLIKE 30W SUNLIKE PRO 30W)</small>	3 =3000K 4 =4000K 5 =5000K 6 =5700K	SF =Slip Fitter	GY =Gray	1 =1 2 =2 <small>(only for SUNLIKE 20W)</small>

For example: STLTWR01ESTLSTC020T33SFGY2

This means the customer wants a Solar Mobile Tower TWINKO, SUNLIKE 20W, TYPE III, 3000K CCT, Slip Fitter installation, with a Gray finish, and 2 Fixtures.

DO NOT send the sample number directly to our salesperson. Use the information in the chart above to create a model number with the correct series, wattage, temperature, mounting option, and finish for the product that you want.

05 Installation

01. Install Tenon

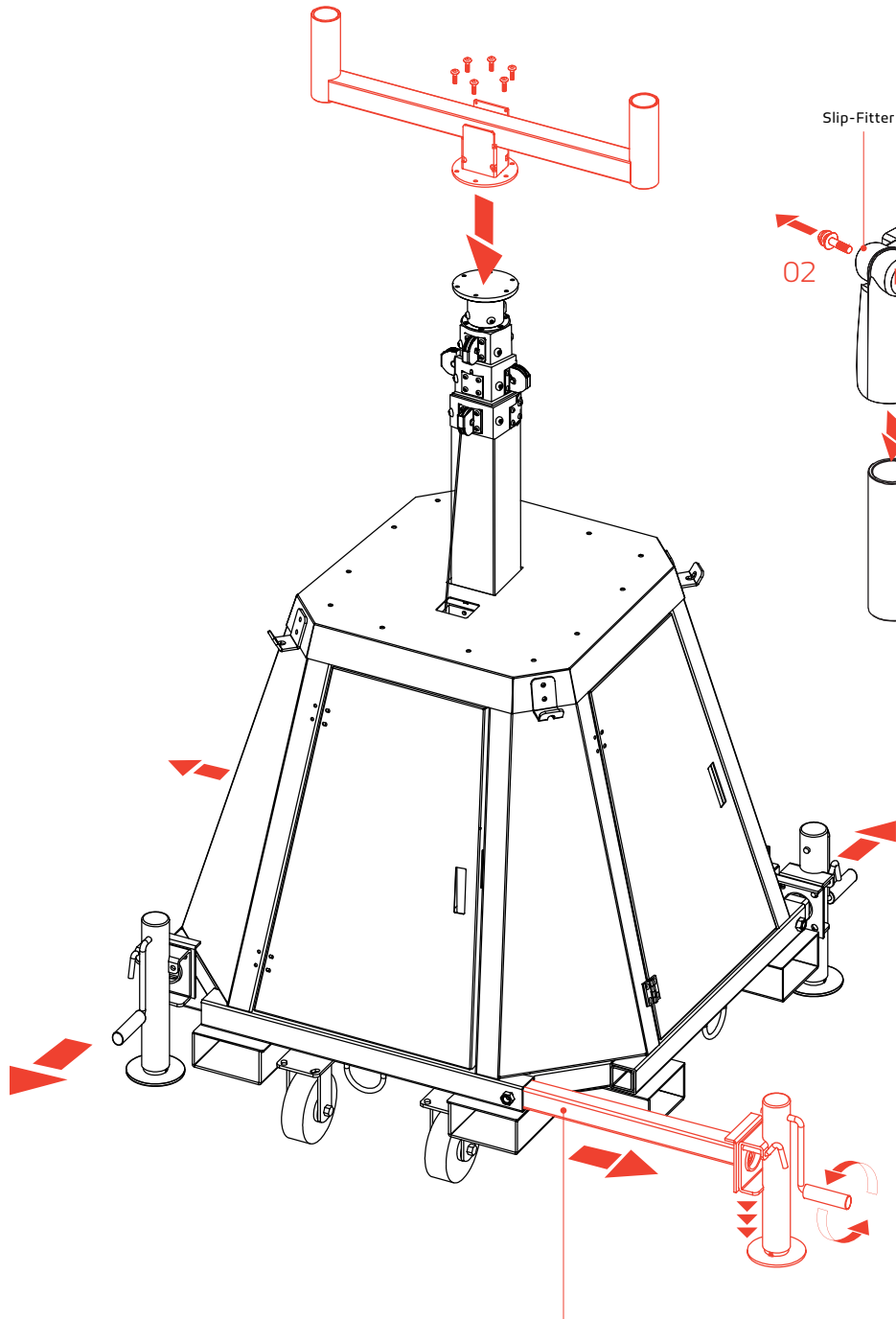

02. Install Luminaire

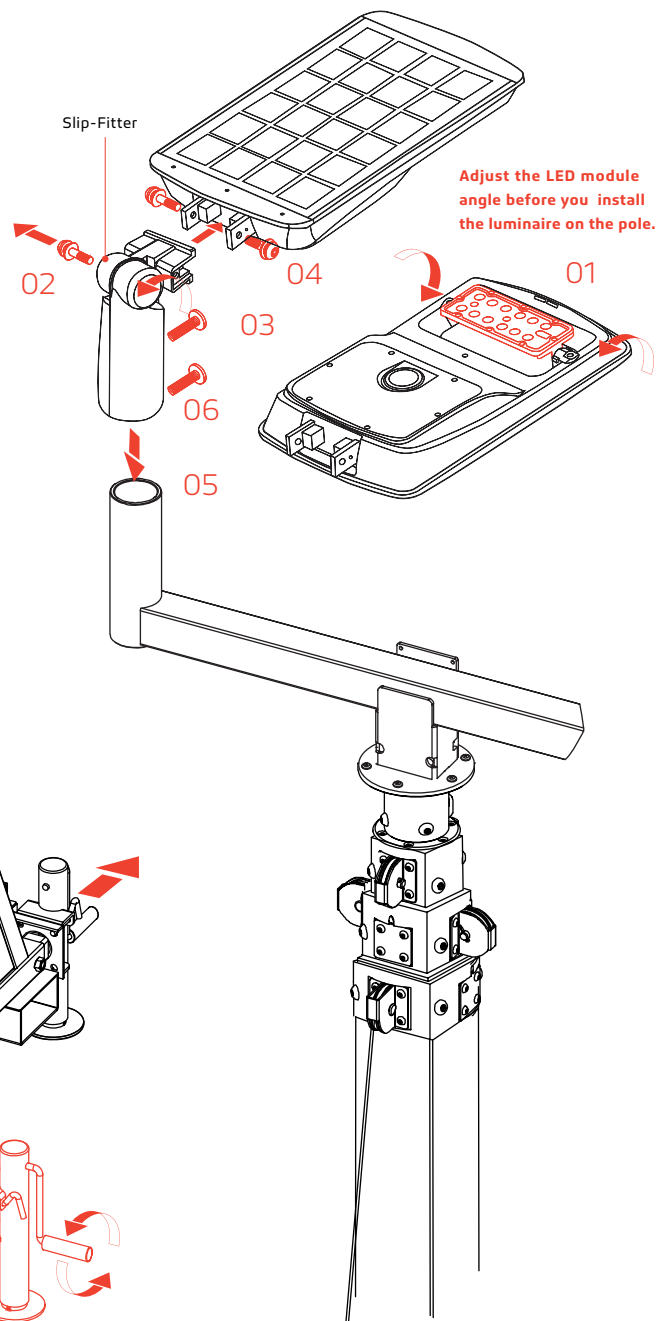

Manual Stabilizer Legs
Pull out the manual stabilizer legs at four directions and rotate handles to set up the TWINKO solar LED mobile light tower on the ground.

03. Adjust The Pole Height

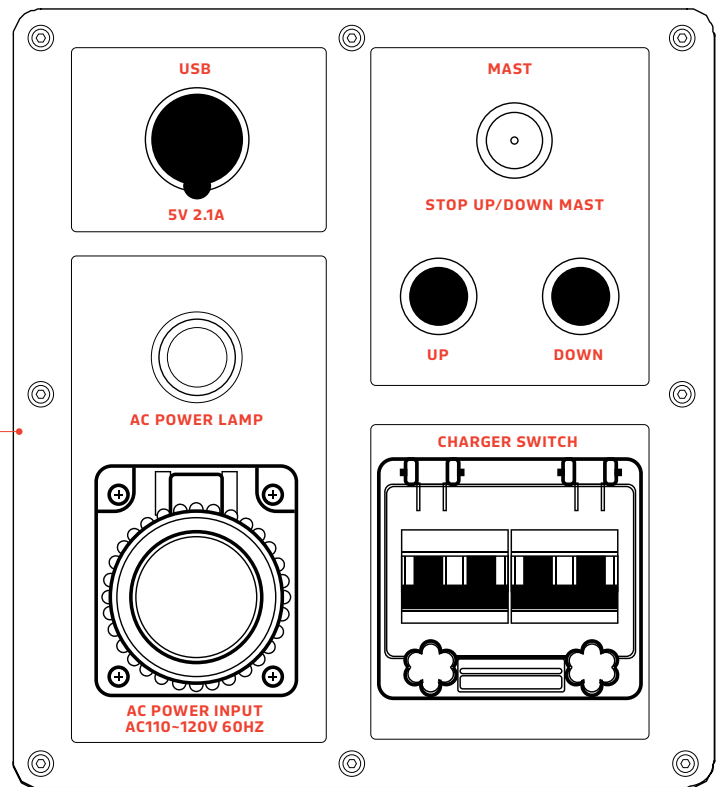
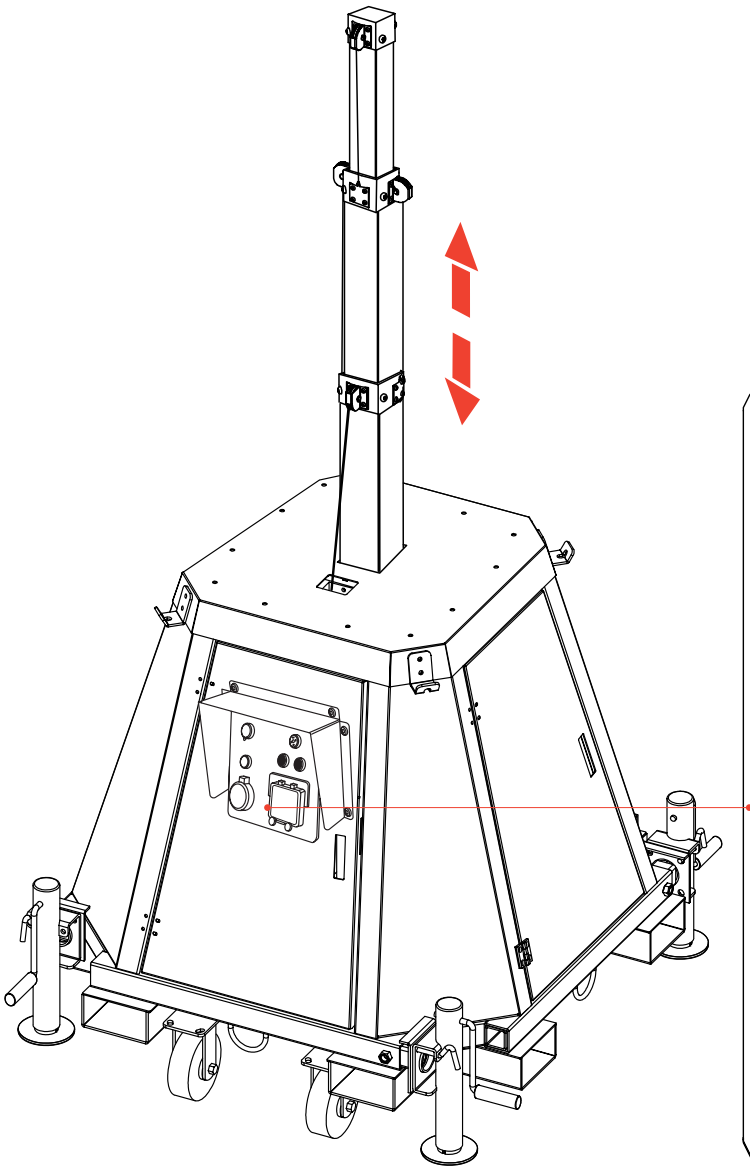

Press the UP and DOWN buttons on the control board to adjust the pole height.

Control Board

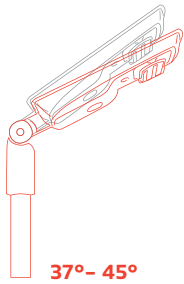

37°- 45°

70° N

69° N
68° N
67° N
66° N

65° N

64° N
63° N
62° N
61° N

60° N

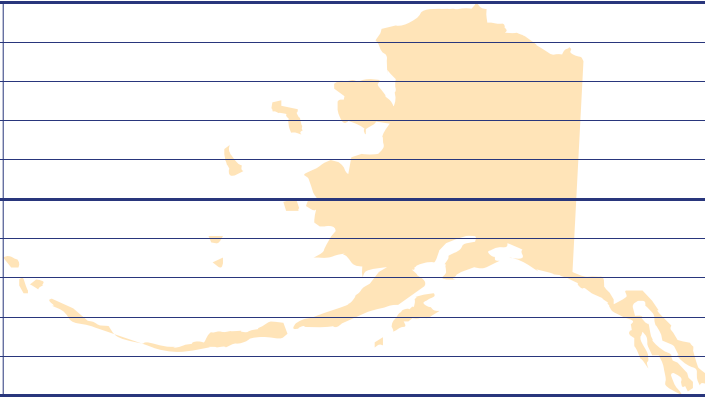

Alaska

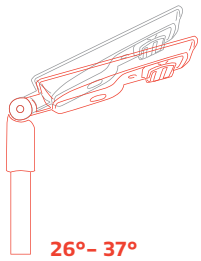

26°- 37°

49° N

48° N
47° N
46° N

45° N

44° N
43° N
42° N

41° N

40° N
39° N
38° N

37° N

36° N
35° N
34° N

33° N

32° N
31° N
30° N

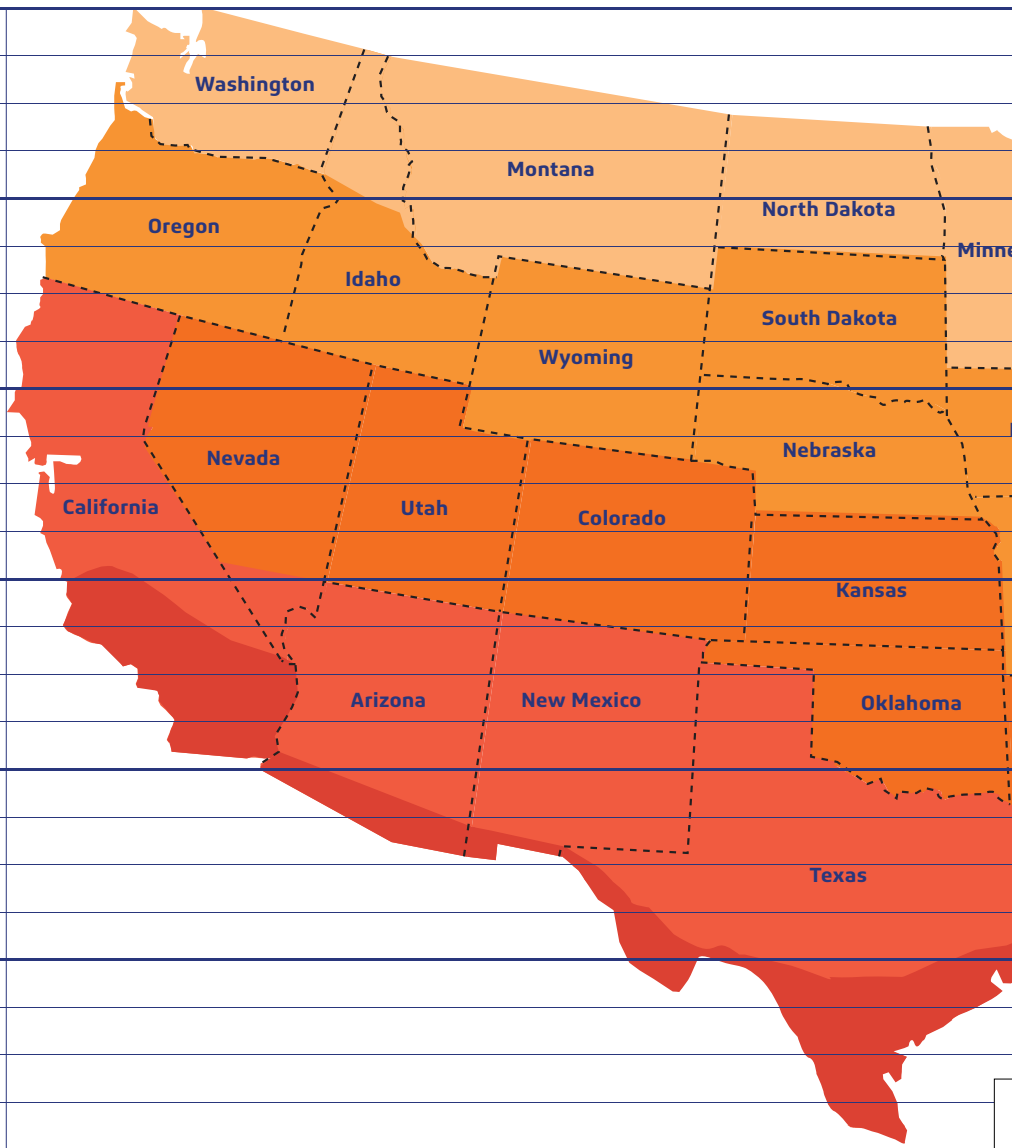

29° N

28° N
27° N
26° N

25° N

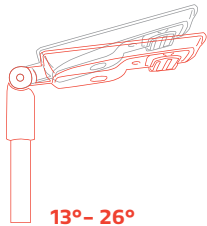

13°- 26°

21° N

20° N

19° N



Hawaii

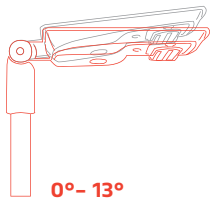

0°- 13°

06 Panel Angle

The Solar charge in a battery pack won't last forever. The off-grid system relies on stored solar energy for autonomy. Angling your solar panels properly can boost the power intake of your solar lighting system. You want to angle your solar panels at a tilt based on the area's latitude.

Tip

You can increase the tilt 15° in the winter or decrease 15° in the summer. In this way you can get the maximum sunlight to recharge the battery bank.

Key



Best Facing Direction of Solar Panel

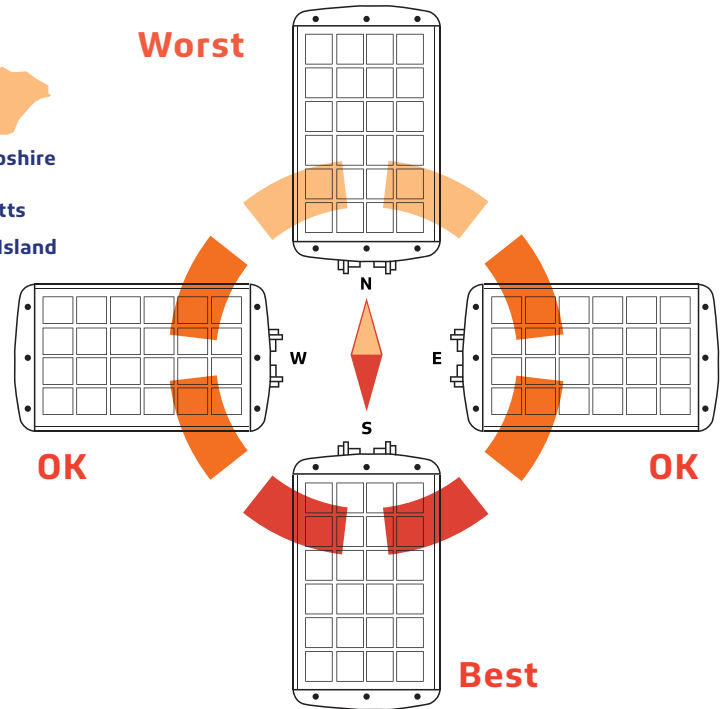

The area will dictate the installation of the fixtures and will sometimes prevent the lights from facing south. But that's okay! Panels facing West & East won't get as much light as Southern facing panels, but will still collect a good amount of sunlight. A North facing panel also works, but it will take longer to charge than any other direction. This would mean that the solar charge will be less optimal if installations are facing North.

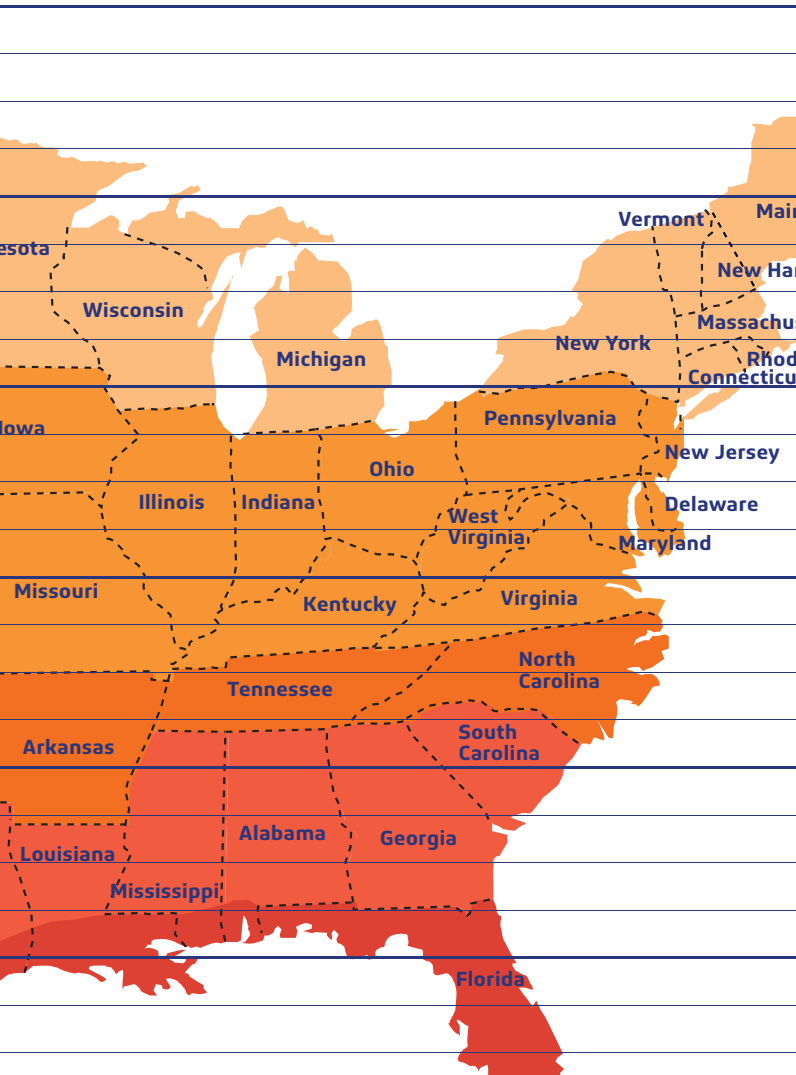

World Wide Panel Angles

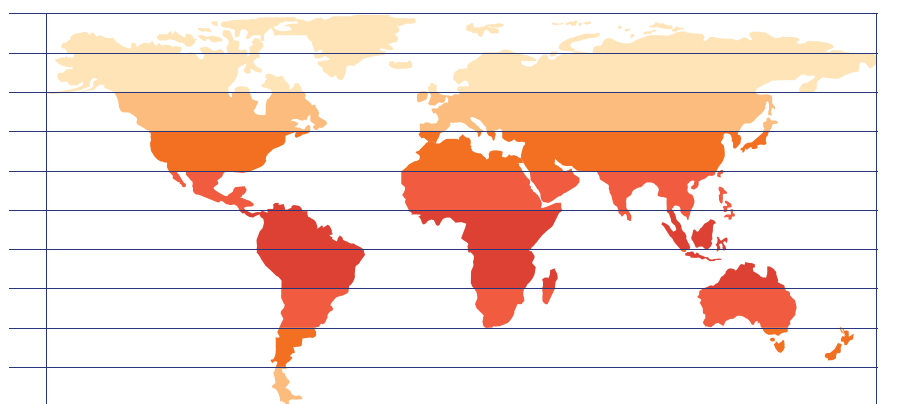
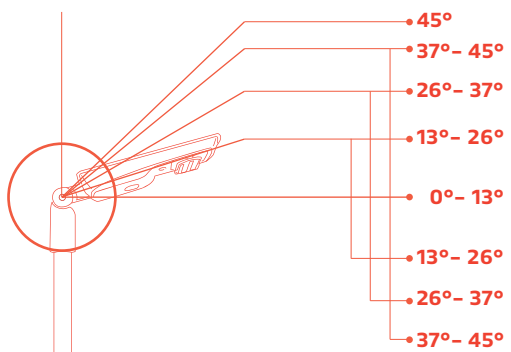

07 Remote Control Guide

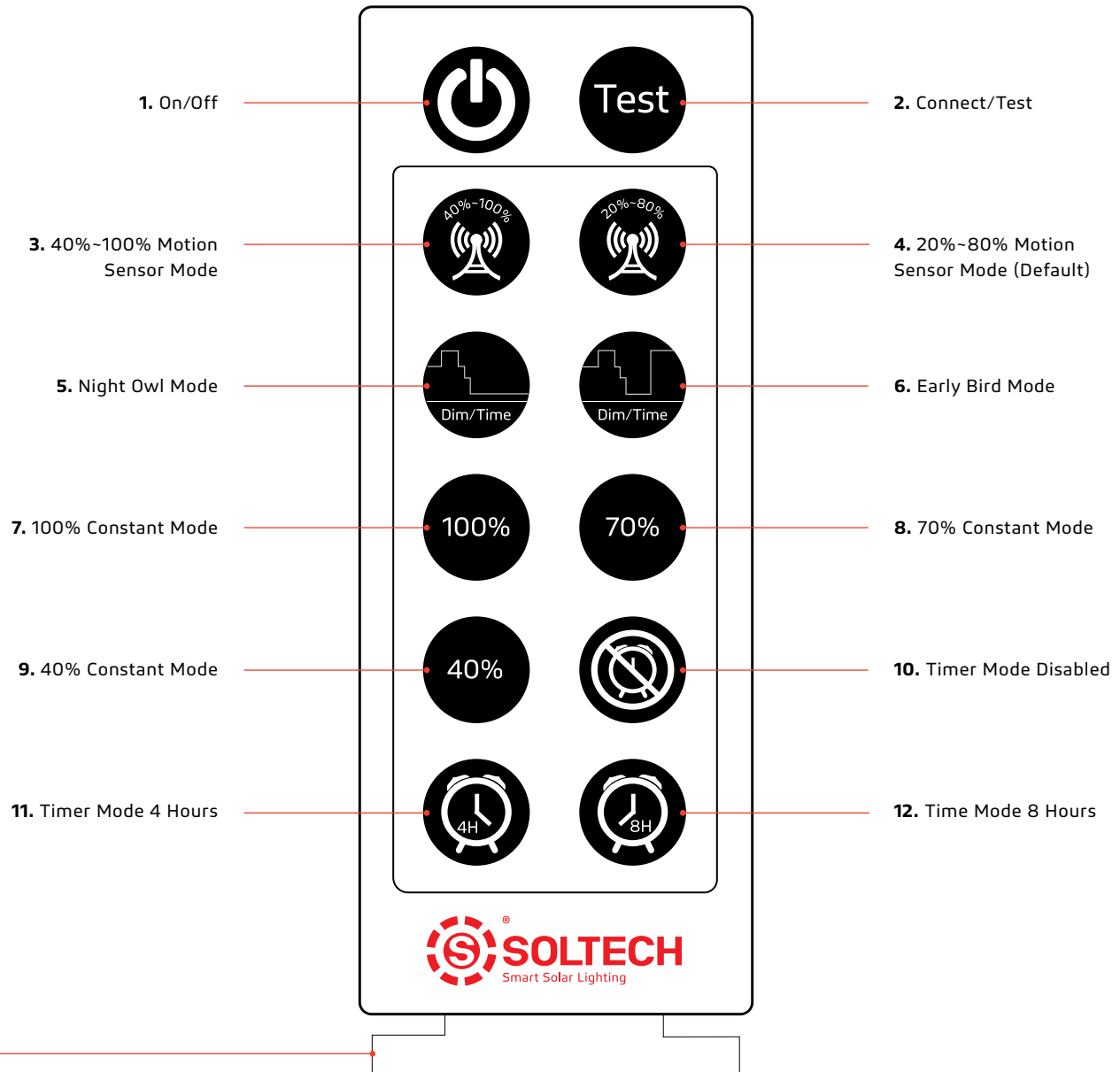

When using the remote for the first time, please remove the plastic piece at the bottom to make the remote turn on.

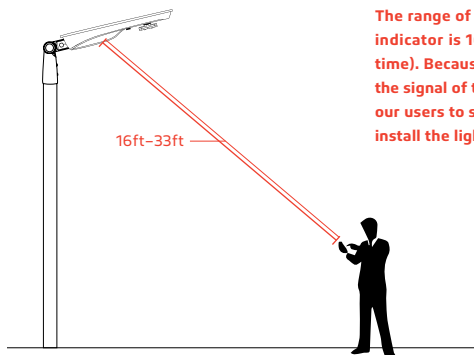

The range of the remote control to the indicator is 16ft (Day time) to 33ft (Night time). Because the sunlight will impact the signal of the remote control, we suggest our users to setup the mode before they install the light.

1. On/Off

When off is selected, the light will stop working. The solar panel will not charge the battery and the battery will not supply electricity to the light.

2. Connect/Test

Remote control device can be connected with any lighting fixture, one at a time. To connect, press the button once. It also functions as a test button. To test, press the "Test" button once, the red light will indicate the fixture is charging, green light indicates that the fixture is operating. Testing lasts for 10 seconds, and then it goes back to the mode previously in use.

3. 40%-100% Motion Sensor Mode

Constant 40% brightness (turns on at dusk, turns off at dawn); 100% brightness turns on for 2 minutes when motion is detected.

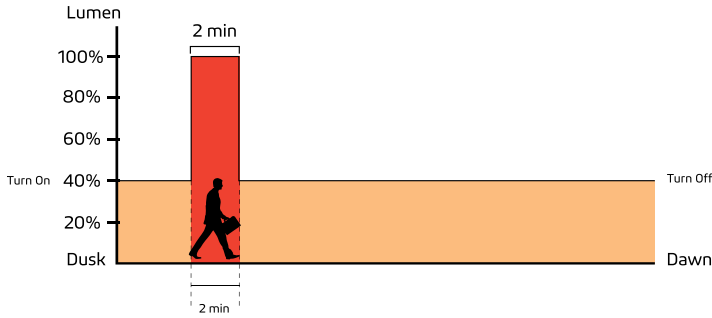

4. 20%-80% Motion Sensor Mode (Default)

Constant 20% brightness (turns on at dusk, turns off at dawn); 80% brightness turns on for 2 minutes when motion is detected.

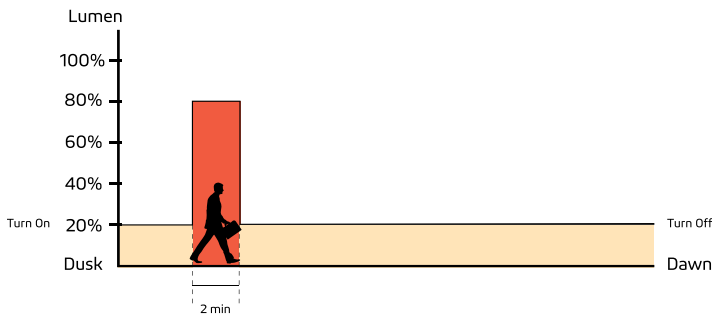

(IAP) Intelligent Adaptive Program Battery Control Technology

In order to extend the off-grid autonomy of the SOLTECH solar products under shady trees, heavy rain, and thick clouds, our controllers now integrate an adaptive smart control feature to actively track battery capacity and adjust light output accordingly. Before integrating this feature, selecting a light output percentage on the remote would yield an accurate percentage of max LED brightness. Now with (IAP), the controller actively monitors the battery and regulates the electrical current to the LEDs. The controller makes light output of the selected percentage on the remote relative to battery capacity rather than max LED output. This smart-control feature can increase our off-grid performance by up to 40%.

5. Night Owl Mode

Changes as natural light decreases/increases (turns on at dusk); 70% brightness for 0.5 hour, 100% brightness for 3.5 hours, 70% brightness for 1 hour, 50% brightness for 1 hour, 20% brightness for 5 hours (turns off at Dawn).

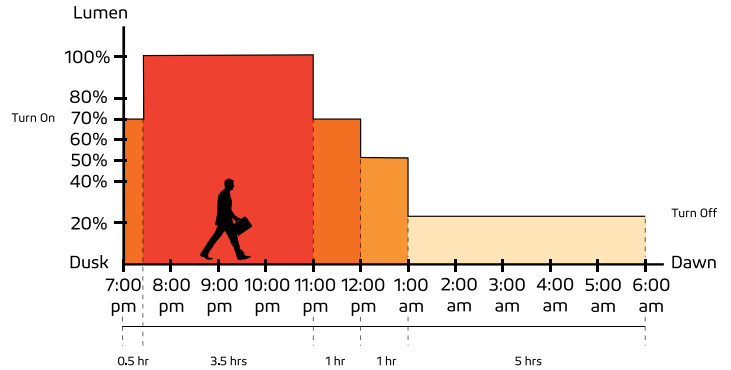

6. Early Bird Mode

Changes as natural light decreases/increases with increased brightness near dawn for early risers (turns on at dusk); 70% brightness for 0.5 hour, 100% brightness for 3.5 hours, 70% brightness for 1 hour, 50% brightness for 1 hour, 20% brightness for 4 hours, 100% brightness for 1 hour (turns off at Dawn).

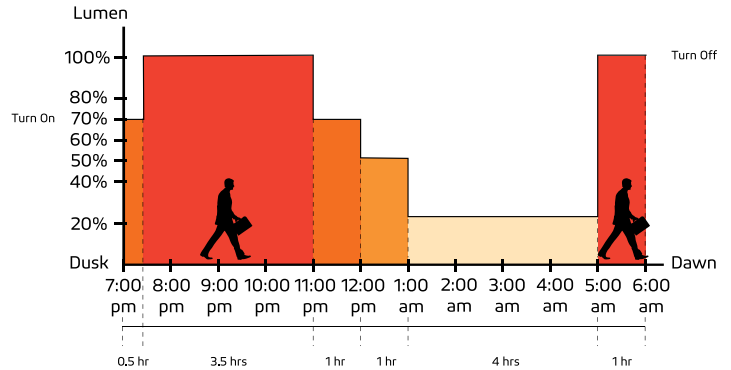

Important

Dusk and dawn time can vary for different locations and seasons. The sensors in our products will monitor the light levels where it is installed. The time period shown in the chart above is just an example to help you understand the different lighting modes.

07 Remote Control Guide

7. 100% Constant Mode

100% brightness from dusk to dawn.

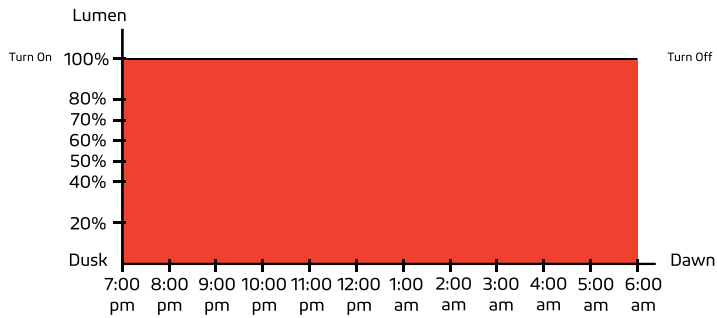

8. 70% Constant Mode

70% brightness from dusk to dawn.

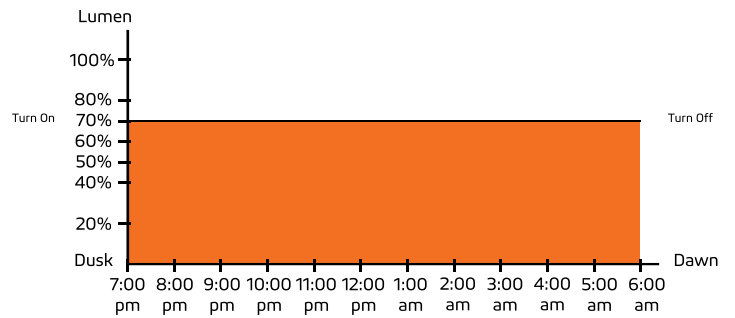

9. 40% Constant Mode

40% brightness from dusk to dawn.

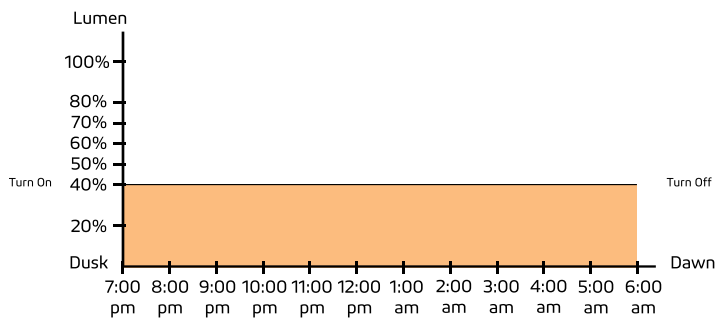

10. Timer Mode Disabled

Press this button to turn off Timer Mode; settings revert back to before Timer Mode was last activated.

11. Timer Mode 4 Hours

This is an additional mode which can work with any other modes. For example: press this button at any time after you turn on 70% Constant Mode. If the light turns on at 7pm at dusk, it will turn off at 11pm. It will repeat the same schedule hereafter until it is canceled by pressing Timer Mode Disabled.

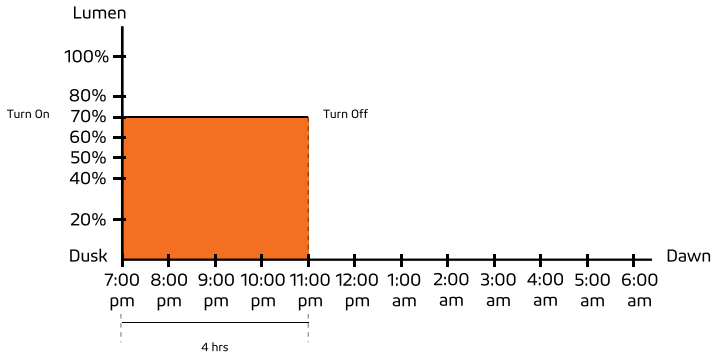

12. Time Mode 8 Hours

This is an additional mode which can work with any other modes. For example: press this button at any time after you turn on 70% Constant Mode. If the light turns on at 7pm at dusk, it will turn off at 3am. It will repeat the same schedule hereafter until it is canceled by pressing Timer Mode Disabled.

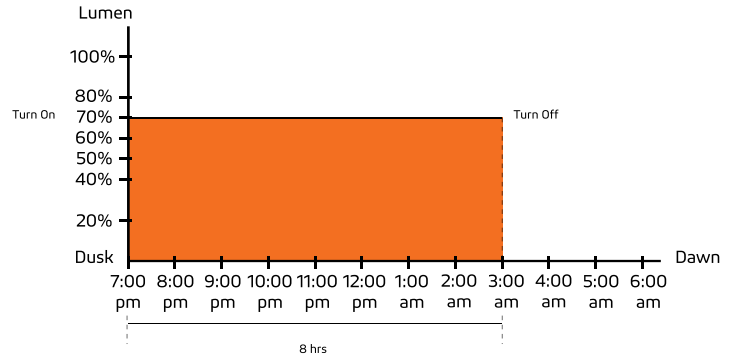

Important

Dusk and dawn time can vary for different locations and seasons. The sensors in our products will monitor the light levels where it is installed. The time period shown in the chart above is just an example to help you understand the different lighting modes.

TWINKO Solar Light Mobile Tower products are covered by a 5 year limited warranty. SOLTECH warrants to the original purchaser that this product is free from defects in materials and workmanship for the period of 5 years from date of purchase. To obtain warranty service please contact your local distributor or sales rep for further instruction.



1460 Park Avenue.
Emeryville, CA 94608 USA

soltechlighting.com

SOLTECH LLC reserves the right to update all product data sheets at any time. Consult SOLTECH marketing specialists for publication updates at hello@soltechlighting.com

*Copyright©2022-2023 SOLTECH LLC,
All Rights Reserved.*

**SOLTECH Provides
Advanced LED
Technology Powered
With Eco-friendly,
Clean, Solar Energy.**