

SATELIS

Solar Area Lights



SATELIS meets the lighting requirements for major roads and highways. Equipped with more powerful solar panels and higher capacity lithium battery packs to ensure battery run time, SATELIS is the spec-grade LED solar lighting solution for most commercial applications.



For more information, please visit our website:
www.soltechlighting.com

APPLICATIONS

50W, 75W SATELIS BAA Area Lights

This commercial-grade series is ideal for highways, city streets, large parking lots and area lighting. It comes with a wide choice of configurations, lumen outputs, pole heights, and it's optimized for high efficiency and long-term performance.



Stariha Dr.
North Shores, MI
Parking Lot Lighting Project

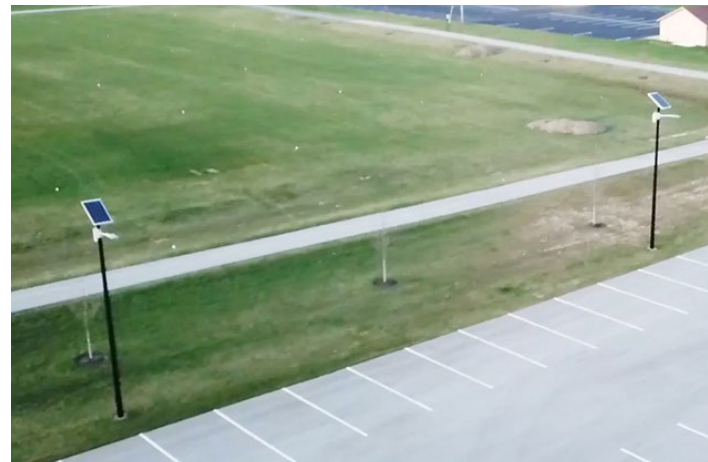

South Main Street
Jackson Center, OH
Parking Lot Lighting Project



12380 Kirk Rd,
Olive Branch, MS
Parking Lot Lighting Project



Vicksburg
Michigan, USA
Parking Lot Lighting Project

FEATURES

50W, 75W SATELIS BAA Area Lights



Powerful Panel & Powerful Lighting

- 2*130W Dual Panels and 2*75W Dual lighting head option
- 15,000LM at 200 LM/W highest efficiency in the industry
- Remote control included with one-button mode settings

Longer Life & Heavy Duty

- Grade A LifePO₄ Battery Pack up to 25V*90AH, 2000+ full Charging Cycles
- LEVEL 12 Wind Test

Modular & Customizable Concept

- Modular battery box with fast hooking design and IP68 underground options
- Top mounting or under mounting panel options
- Reduce the construction time for building projects
- TYPE III distribution comes standard. TYPE II and TYPE V are also available.

Standardized Lighting Design

- Illumination where you need it with scheduled dimming
- Meets IES standards for road illumination
- Solar clean energy solution that also meets street and area light compliances



DIMENSIONAL DRAWINGS

SATELIS BAA 50W

25V 30AH

SOLAR PANEL: 21.1 Lbs
SOLAR LAMP: 13.5 Lbs
BATTERY ASSEMBLY: 35.2 Lbs
MOUNTING FASTNER: 22 Lbs

25V 60AH

SOLAR PANEL: 21.1 Lbs
SOLAR LAMP: 13.5 Lbs
BATTERY ASSEMBLY: 51 Lbs
MOUNTING FASTNER: 22 Lbs

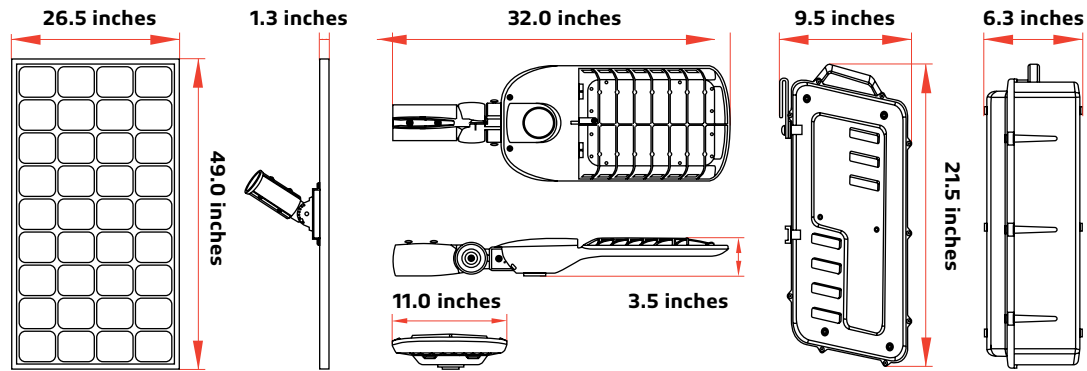

SATELIS BAA 75W

25V 60AH

SOLAR PANEL: 42.2 Lbs
SOLAR LAMP: 13.8 Lbs
BATTERY ASSEMBLY: 51 Lbs
MOUNTING FASTNER: 28.6 Lbs

25V 90AH

SOLAR PANEL: 42.2 Lbs
SOLAR LAMP: 13.8 Lbs
BATTERY ASSEMBLY: 66 Lbs
MOUNTING FASTNER: 28.6 Lbs

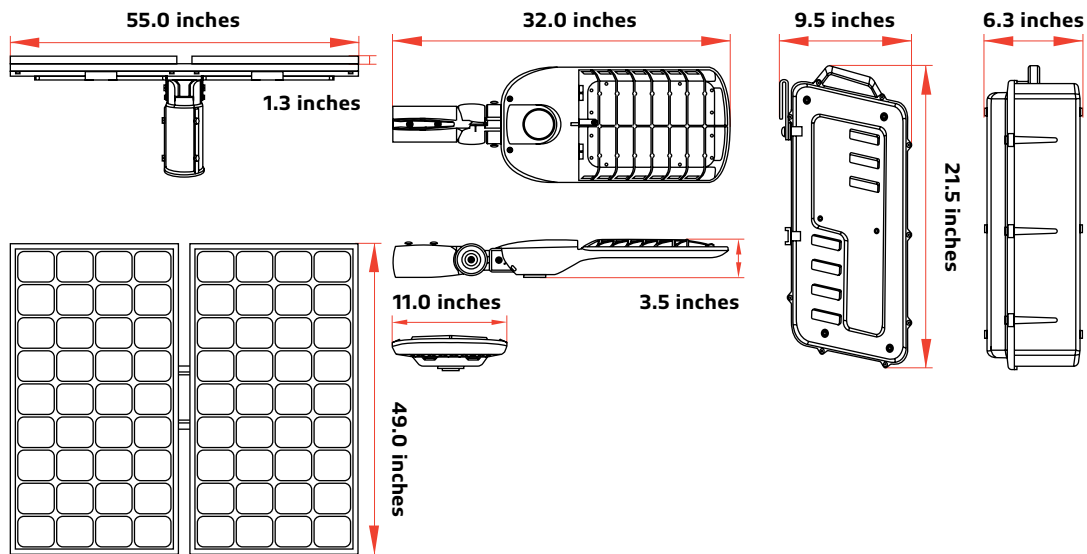

SPECIFICATIONS & PERFORMANCE

50W, 75W SATELIS BAA Area Lights

SATELIS Series is designed to withstand the most extreme weather and harsh environments. Featuring a 50–150 watt LED fixture, up to 2 solar panels, and an output of up to 15,000 lumens, Satelis is perfect for most commercial applications.

| SPECIFICATIONS | SATELIS BAA 50W | | SATELIS BAA 75W | |
|-----------------------------|------------------------------------|------------------------------------|------------------------------------|------------------------------------|
| | 50W | 50W | 75W | 75W |
| LED NOMINAL POWER | 50W | 50W | 75W | 75W |
| SOLAR PANEL | 36V 130W | 36V 130W | 36V 260W | 36V 260W |
| LIFEPO ₄ BATTERY | 768WH 25.6V 30AH | 1536WH 25.6V 60AH | 1536WH 25.6V 60AH | 2304WH 25.6V 90AH |
| WEIGHT | 91.8 Lbs | 107.6 Lbs | 135.6 Lbs | 150.6 Lbs |
| LUMEN OUTPUT@5000K | 10,000 | 10,000 | 15,000 | 15,000 |
| IP RATING | IP65 | IP65 | IP65 | IP65 |
| CRI | CRI > 70 (>80 Optional) | CRI > 70 (>80 Optional) | CRI > 70 (>80 Optional) | CRI > 70 (>80 Optional) |
| CASTING | ALUMINUM | ALUMINUM | ALUMINUM | ALUMINUM |
| EFFICIENCY@5000K | 200 LM/W | 200 LM/W | 200 LM/W | 200 LM/W |
| LED CHIP | Lumileds 5050 (215 LM-CR>70) | Lumileds 5050 (215 LM-CR>70) | Lumileds 5050 (215 LM-CR>70) | Lumileds 5050 (215 LM-CR>70) |
| * CHARGING TIME | 6 Hrs | 12 Hrs | 5 Hrs | 9 Hrs |
| RUN TIME (@FULL POWER) | 15 Hrs | 30 Hrs | 20 Hrs | 30 Hrs |
| OPERATION MODE | REMOTE CONTROL AND ONE-KEY SETTING | REMOTE CONTROL AND ONE-KEY SETTING | REMOTE CONTROL AND ONE-KEY SETTING | REMOTE CONTROL AND ONE-KEY SETTING |
| INSTALLATION HEIGHT | 15 to 20 ft | 15 to 20 ft | 15 to 20 ft | 15 to 20 ft |
| * OPERATING TEMPERATURE | -20°C/-4°F to 122°F | -20°C/-4°F to 122°F | -20°C/-4°F to 122°F | -20°C/-4°F to 122°F |
| * CHARGING TEMPERATURE | 0°C/32°F to 149°F | 0°C/32°F to 149°F | 0°C/32°F to 149°F | 0°C/32°F to 149°F |

* The temperature can impact the battery's charging and normal operation.

* The solar charge time data is based on 77 degree F ambient temperature with the panel pointed directly at the solar radiation. The standard radiation value is 1000W/m².

PHOTOMETRY

SATELIS BAA 50W

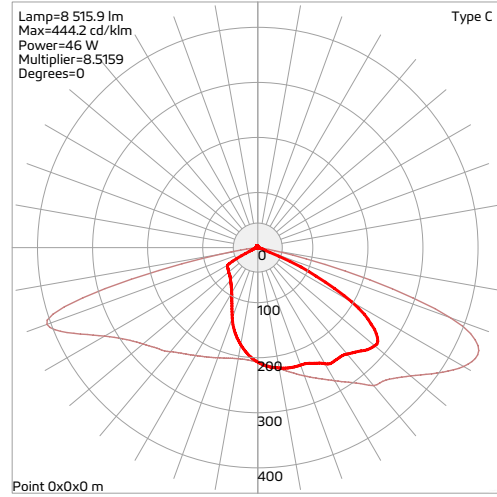

SATELIS BAA 75W

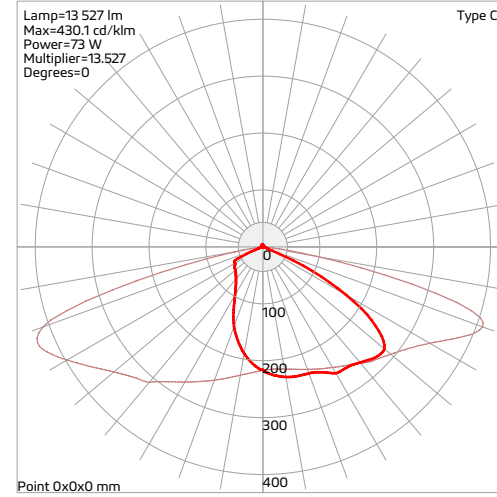

PRODUCT NUMBER BUILDER

Example: **STLSTDBAA503SFGY60**

This example product number is for SATELIS BAA 50 watt, 3000K CCT, Slip Fitter installation, with a gray finish and 60AH battery capacity.

| SERIES | WATTAGE | COLOR TEMPERATURE | MOUNTING OPTIONS | FINISH | BATTERY CAPACITY |
|----------------------------------|--|--|------------------------|--------------------------------------|---|
| STLSTDBAA =SATELIS BAA | 50 =50W 10000 LUMENS 75 =75W 15000 LUMENS | 3 =3000K 4 =4000K 5 =5000K 6 =5700K | SF =SLIP FITTER | GY =GRAY BR =BRONZE | 30 =30AH <i>(only for SATELIS 50W)</i> 60 =60AH 90 =90AH <i>(only for SATELIS 75W)</i> |

- - - - -

Sample Number: STLSTDBAA50XYZZEE

Please **DO NOT** send the generic sample number directly to our salesperson. Use the information in the chart, above, to create a model number with the correct series, wattage, CCT, mounting options, and finish for the product options that you want.

MOUNTING ACCESSORIES (50W, 75W)



SLIP FITTER

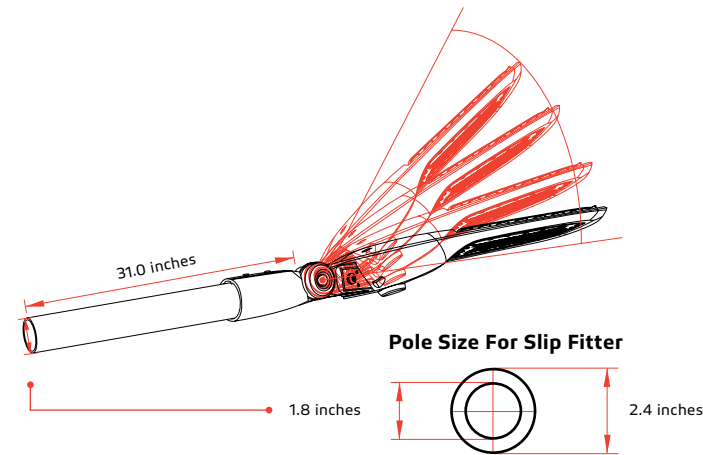

SOLAR PANEL SUPPORT BASE—CUTAWAY

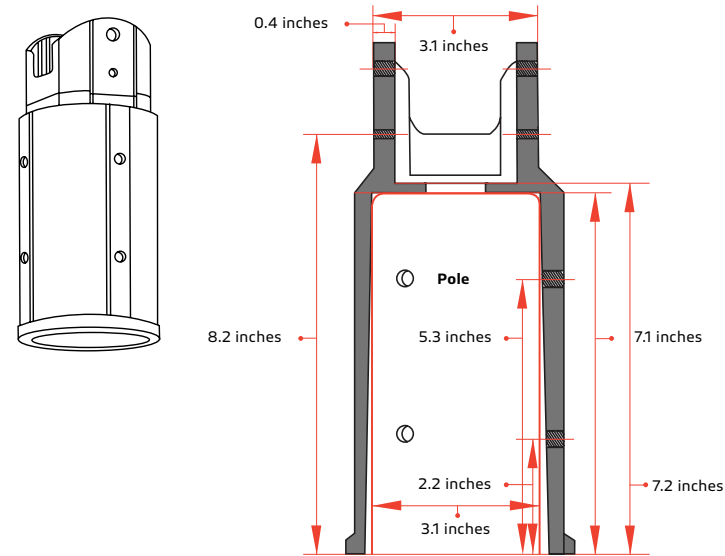

POLE ASSEMBLY

Create 2 holes (0.5 inch diameter) in the middle of the pole, create another slotted hole (1.5 inch diameter, 2.6 inches long) between the 2 holes.

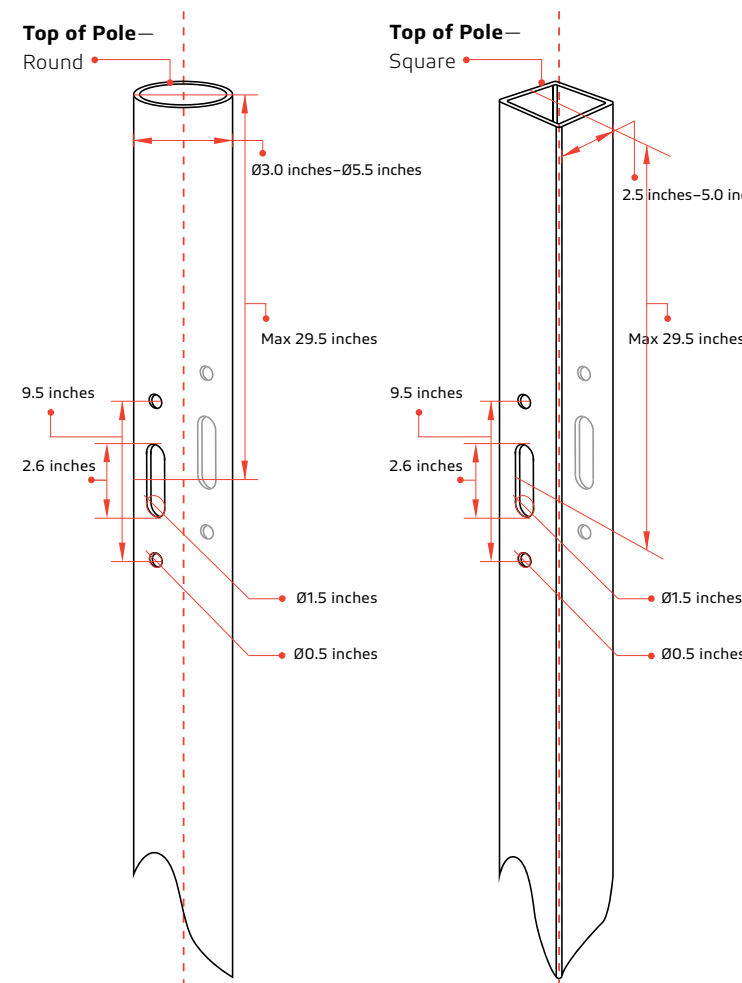

TENON ADAPTER

If your round pole size is over 3.1 inches, or you use a square pole, please contact the pole manufacturer for the tenon adapter.

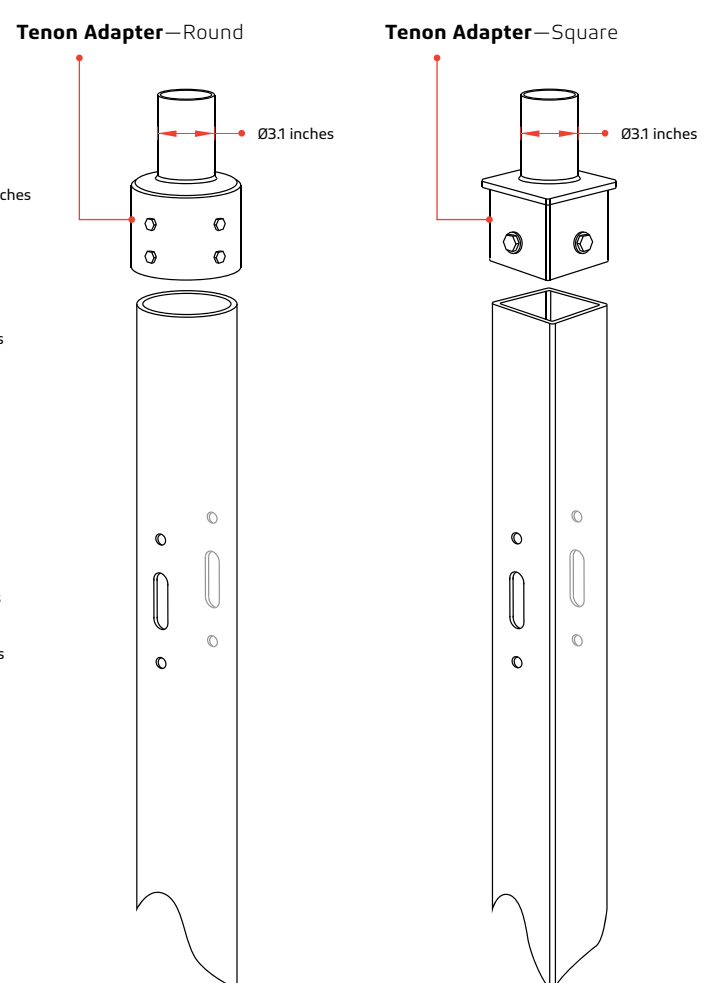

(50W)

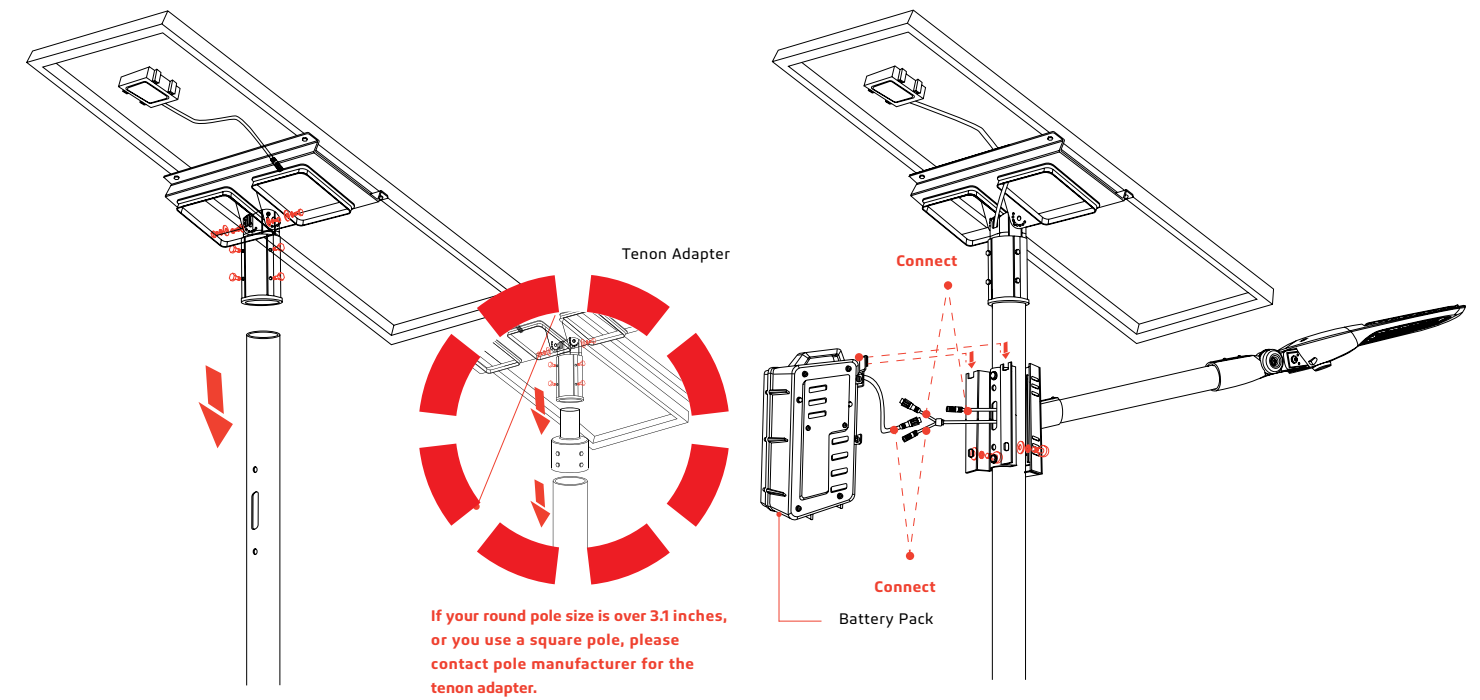

(75W)

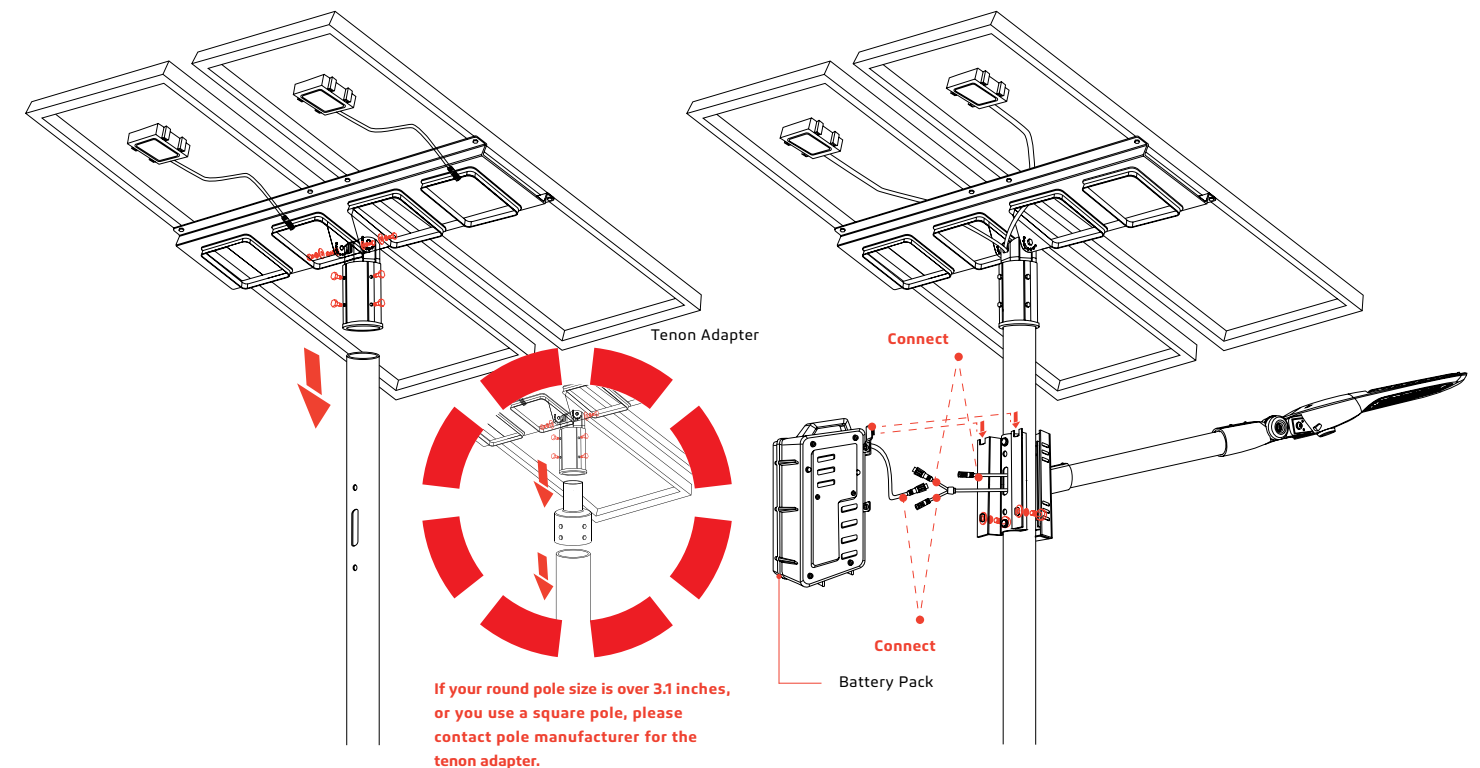

REMOTE CONTROL GUIDE

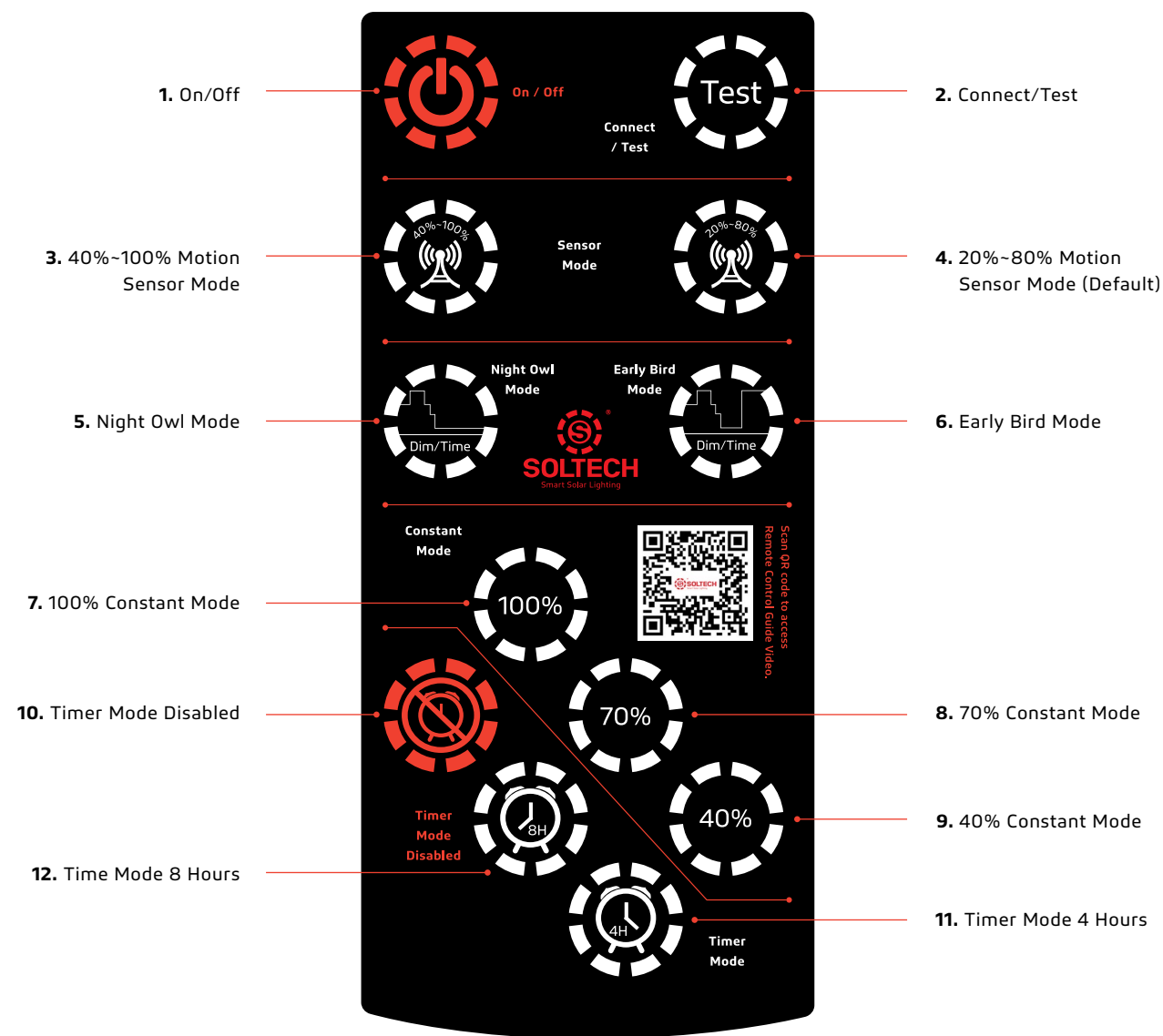

3. 40%~100% Motion Sensor Mode

Constant 40% brightness (turns on at dusk, turns off at dawn); 100% brightness turns on for 2 minutes when motion is detected.

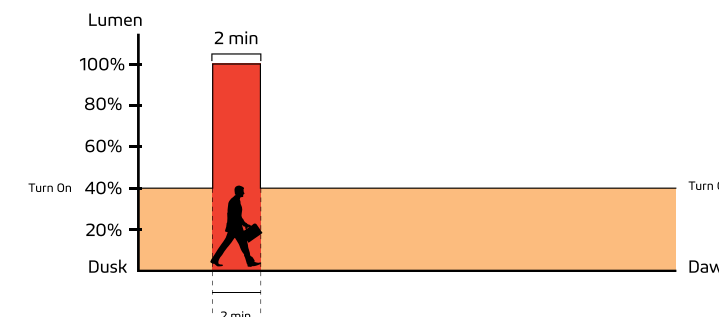

4. 20%~80% Motion Sensor Mode (Default)

Constant 20% brightness (turns on at dusk, turns off at dawn); 80% brightness turns on for 2 minutes when motion is detected.

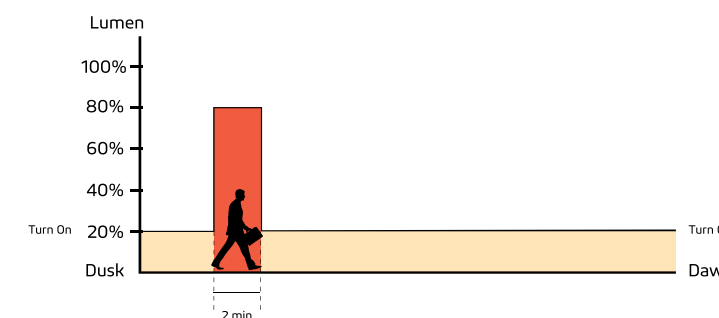

5. Night Owl Mode

Changes as natural light decreases/increases (turns on at dusk); 70% brightness for 0.5 hour, 100% brightness for 3.5 hours, 70% brightness for 1 hour, 50% brightness for 1 hour, 20% brightness for 5 hours (turns off at Dawn).

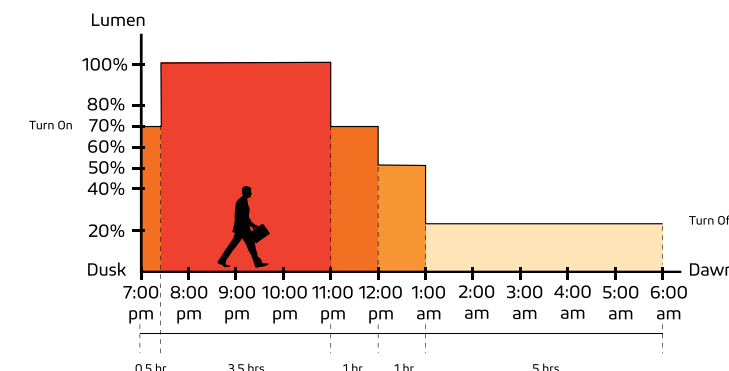

6. Early Bird Mode

Changes as natural light decreases/increases with increased brightness near dawn for early risers (turns on at dusk); 70% brightness for 0.5 hour, 100% brightness for 3.5 hours, 70% brightness for 1 hour, 50% brightness for 1 hour, 20% brightness for 4 hours, 100% brightness for 1 hour (turns off at Dawn).

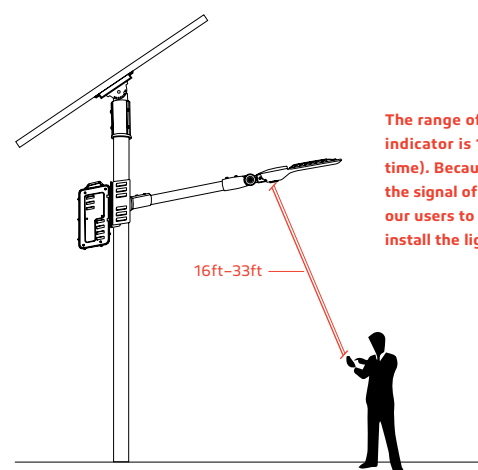
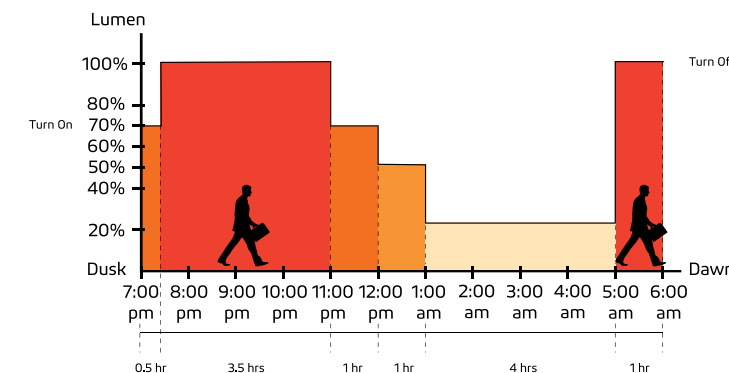

The range of the remote control to the indicator is 16ft (Day time) to 33ft (Night time). Because the sunlight will impact the signal of the remote control, we suggest our users to setup the mode before they install the light.

1. On/Off

When off is selected, the light will stop working. The solar panel will not charge the battery and the battery will not supply electricity to the light.

2. Connect/Test

Remote control device can be connected with any lighting fixture, one at a time. To connect, press the button once. It also functions as a test button. To test, press the "Test" button once, the red light will indicate the fixture is charging, green light indicates that the fixture is operating. Testing lasts for 10 seconds, and then it goes back to the mode previously in use.

(IAP) Intelligent Adaptive Program Battery Control Technology

In order to extend the off-grid autonomy of solar products under shade trees, heavy rain, and thick clouds, our controllers now integrate an adaptive smart control feature to actively track battery capacity and adjust light output accordingly. Before integrating this feature, selecting a light output percentage on the remote would yield an accurate percentage of max LED brightness. Activating the IAP, the controller actively monitors the battery and regulates the electrical current to the LEDs. The controller makes the light output of a selected percentage on the remote relative to battery capacity rather than max LED output. This smart-control feature can increase the fixture's off-grid performance by up to 40%.

Important

Dusk and dawn time can vary for different locations and seasons. The sensors in our products will monitor the light levels where it is installed. The time period shown in the chart above is just an example to help you understand the different lighting modes.

REMOTE CONTROL GUIDE

7. 100% Constant Mode

100% brightness from dusk to dawn.

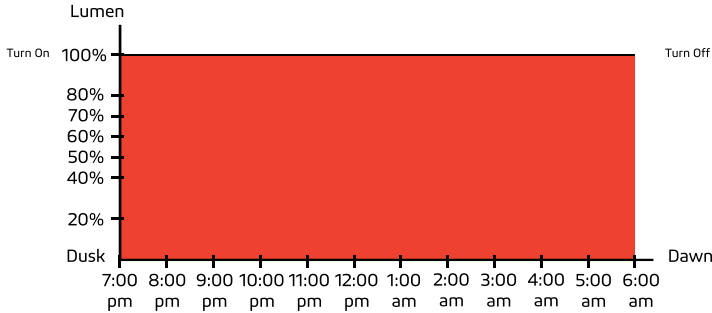

8. 70% Constant Mode

70% brightness from dusk to dawn.

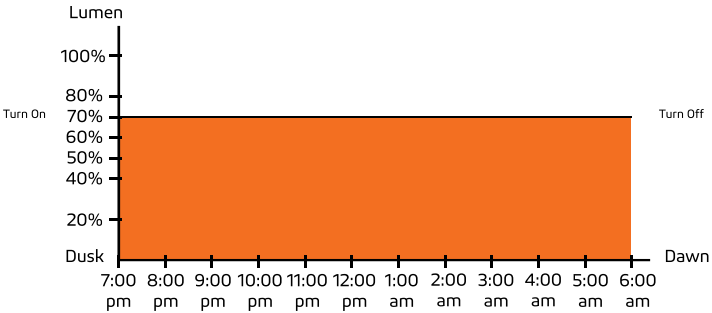

9. 40% Constant Mode

40% brightness from dusk to dawn.

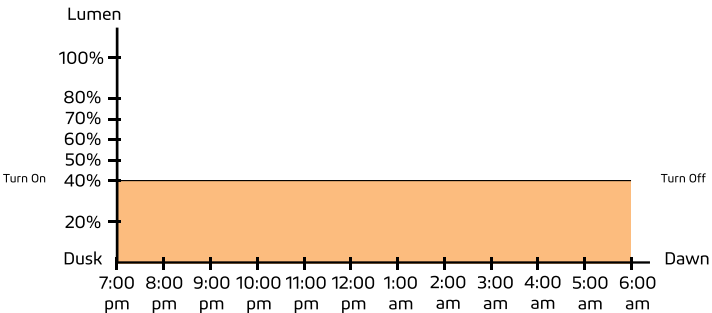

10. Timer Mode Disabled

Press this button to turn off Timer Mode; settings revert back to before Timer Mode was last activated.

11. Timer Mode 4 Hours

This is an additional mode which can work with any other modes. For example: press this button at any time after you turn on 70% Constant Mode. If the light turns on at 7pm at dusk, it will turn off at 11pm. It will repeat the same schedule hereafter until it is canceled by pressing Timer Mode Disabled.

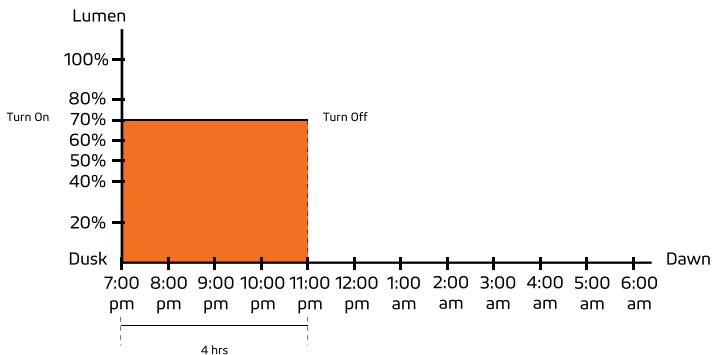

12. Time Mode 8 Hours

This is an additional mode which can work with any other modes. For example: press this button at any time after you turn on 70% Constant Mode. If the light turns on at 7pm at dusk, it will turn off at 3am. It will repeat the same schedule hereafter until it is canceled by pressing Timer Mode Disabled.

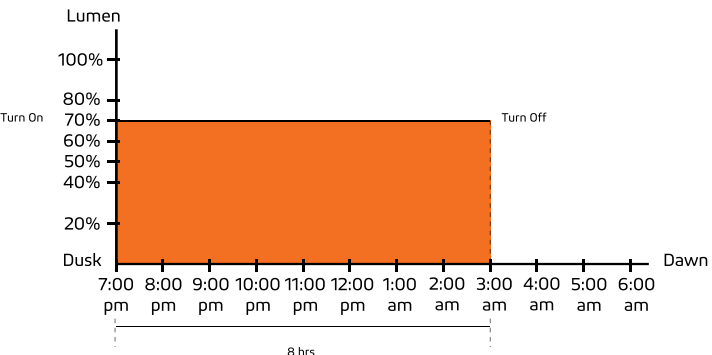

Important

Dusk and dawn time can vary for different locations and seasons. The sensors in our products will monitor the light levels where it is installed. The time period shown in the chart above is just an example to help you understand the different lighting modes.