

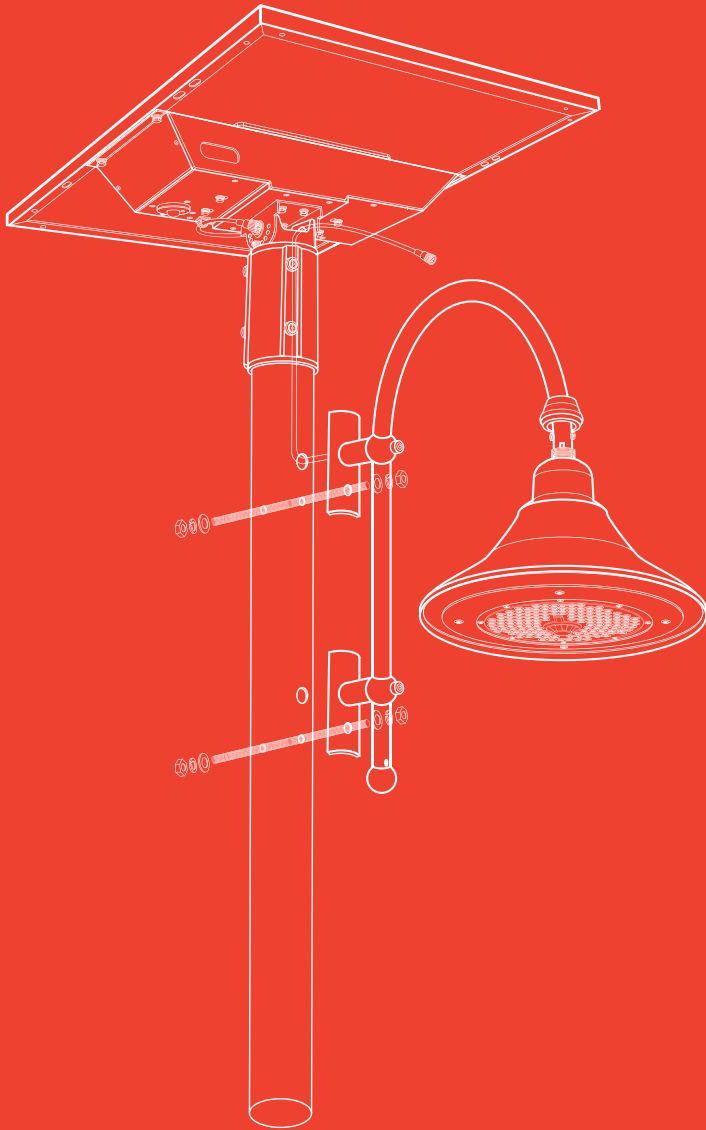

# ORINDA

25W/50W Single Head  
**Installation Manual**

SOLTECH Designs and Manufactures  
Advanced, Solar-Powered  
LED Technology.



# Contents

---

01 Introduction	03
02 Battery Notes	04
03 Installation and Wiring Compliance	05
04 Mounting Accessories	05
05 Installation	06
06 Panel Angle	09
07 Remote Control Guide	10

**ORINDA**  
25W/50W  
Single Head

# 01 Introduction

Thank you for purchasing the **ORINDA Urban Solar Light**

## Introduction

Outdoor solar lighting systems use solar cells which convert sunlight into electricity. Electricity is stored in batteries for use at night. ORINDA solar lights are easy to install, maintenance free, and eliminate electricity bills.

## Important

Install the light in an area that receives ample sunlight. We recommend an average of at least 3.5 hours of sunshine per day. Choose the operating mode that aligns with local regulations and sunlight availability in your area. Position the light away from shaded areas. For self-cleaning functionality, ensure the light fixture is installed at a minimum angle of 15 degrees.

Please save these instructions. Read all of the instructions carefully before attempting to carry out any installation or wiring. Do not open or attempt to repair the product on your own, as it may cause serious

damage and would void the product warranty. Contact your local distributor for any questions concerning the installation.

Range of the light module on the lighting fixture is 20–26 feet (6–8 meters). The ideal installation spacing is >16 feet (5 meters). When installing two or more lighting fixtures on one pole, select desired operating mode before installation. Interference can cause delay or malfunction when using the remote control to change operating modes after installation.

## Precautions when working with solar panels

When the solar panel is exposed to sunlight, a voltage appears at the output terminals of the solar panel turning it into a source of electricity. To avoid a shock hazard, make sure the solar panel is covered with an opaque (dark) material such as cardboard or cloth during the installation. Do not make contact with the terminals when the panel is exposed to sunlight or any other light source.

**ORINDA 25W**

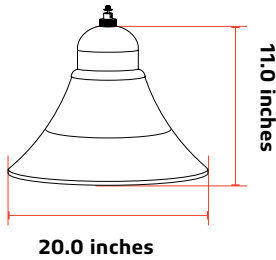

### Weight Information

Battery and Solar Panel: 48lbs

Solar Lamp: 12lbs

Mounting Bracket: 6lbs

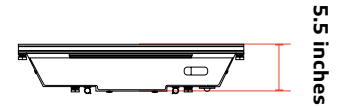
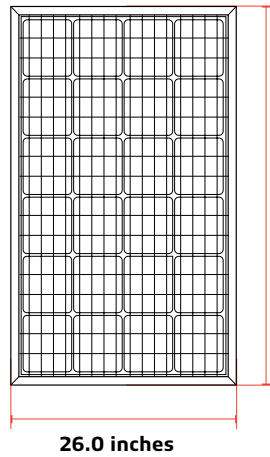
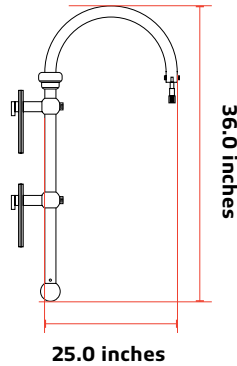

**ORINDA 50W**

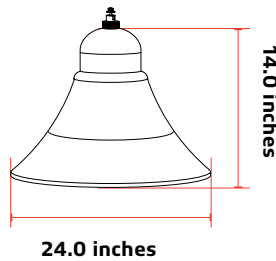

### Weight Information

Battery and Solar Panel: 48lbs

Solar Lamp: 16lbs

Mounting Bracket: 6lbs

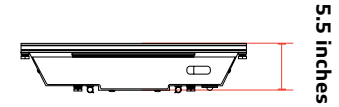
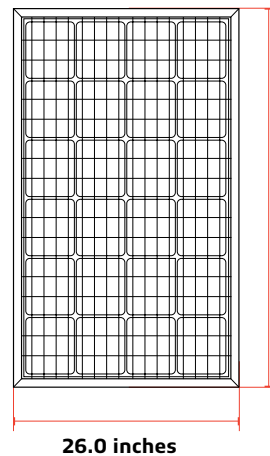
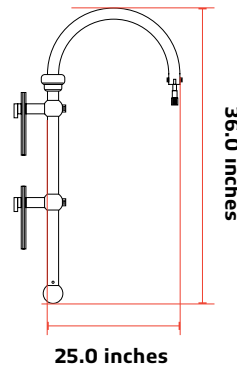

# 02 Battery Notes

---

1. The Lithium-ion-battery(LiFePO<sub>4</sub>)-powered ORINDA lights are visibly brighter than other outdoor solar lights, and their performance overall is more reliable.
2. To charge the battery fully may take up 6 to 12 hours.
3. The rechargeable battery can work continuously for 10 hours at full power.
4. Output will be reduced to 40% when the battery is below 40% of its capacity.
5. Battery will stop charging when the ambient temperature is below 32°F or above 149°F.

## (IAP) Intelligent Adaptive Program Battery Control Technology

In order to extend the off-grid autonomy of the ORINDA under shady trees, heavy rain, and thick clouds, our controllers now integrate an adaptive smart control feature to actively track battery capacity and adjust light output accordingly. Before integrating this feature, selecting a light output percentage on the remote would yield an accurate percentage of max LED brightness. Now with (IAP), the controller actively monitors the battery and regulates the electrical current to the LEDs. The controller makes light output of the selected percentage on the remote relative to battery capacity rather than max LED output. This smart-control feature can increase our off-grid performance by up to 40%.

**Battery Status is indicated by the red/green indicator on the lighting fixture as follows:**

### - Red indicator (Charging)

- > Slow red light flashing = Charging
- > Red light continuously on = fully charged
- > Quick red flashing = charge fault

### - Green indicator (Discharging)

- > Green light continuously on = more than 40% of the battery capacity remaining
- > Slow green light flashing = battery capacity below 10%
- > Quick green light flashing = battery below 0% mode—Protect battery does not over discharging

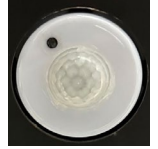

## Storage

To avoid over discharge of the battery during storage, please recharge the lighting fixture every 4 months. Use the dedicated charger to charge, please contact SOLTECH for the dedicated charger details.

## MPPT Controller

- Maximum Power Point Tracking (MPPT) is a technique for tracking and regulating the output energy from the solar panel to the battery.
- Measures the solar panel output voltage and current in real-time and continuously tracks the maximum power.
- Regulates the output voltage so that the system can always charge the battery with the maximum power.
- Significantly improves the solar system energy utilization rate, with a conversion efficiency up to 97%.
- Increases the solar system's charging efficiency by at least 20% compared to Pulse Width Modulation (PWM)

# 03 Installation and Wiring Compliance

1. Installation and wiring must comply with the State and National Electrical Codes.
2. The ORINDA 50W model is intended for outdoor use only and should not be installed in an unventilated area. For optimal performance, ORINDA 50W must be installed in an environment within the operational temperatures defined by the product spec sheet.
3. The average sunshine in the installation area should be above 3.5 hours/day in order to ensure full function of the lighting fixture. Avoid areas with shades.
4. Before installation, if applicable, please ensure the light pole and its foundation are solid enough to withstand the lighting fixture(s).
5. Before installation, please ensure that the battery is charged. Install during sunny days if possible.
6. Before installation, please press the  ON/OFF key in the remote control and check whether it shows a red light on the indicator. Please cover the panel and check if the light module turns on normally within 1 minute.

### After Installation

The lighting fixture is integrated with photocell sensor, will automatically turn on at night and turn off during daylight.

### Important

Always orient the solar panel facing the equator (e.g. facing south if in northern hemisphere).

Always have a tilt angle of at least 15° to avoid dust accumulation (0°=horizontal plane).

# 04 Mounting Accessories

## ROUND POLE MOUNT

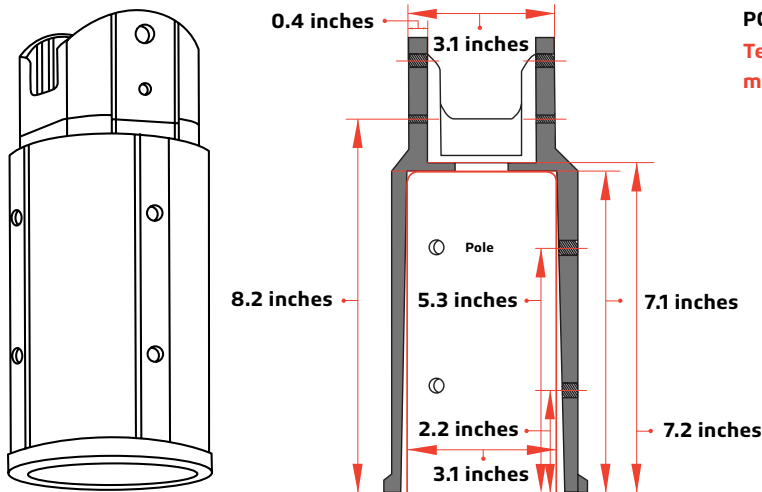

## POLE TENON ADAPTER DIAMENTION

Tenon adapter IS NOT included in the package, please contact the pole manufacturer for the details.

### Tenon Adapter—Round

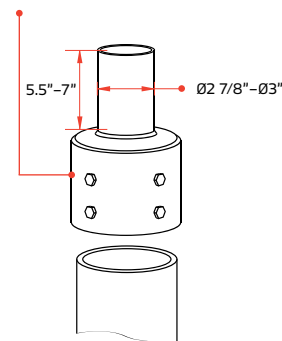

# 05 Installation

01

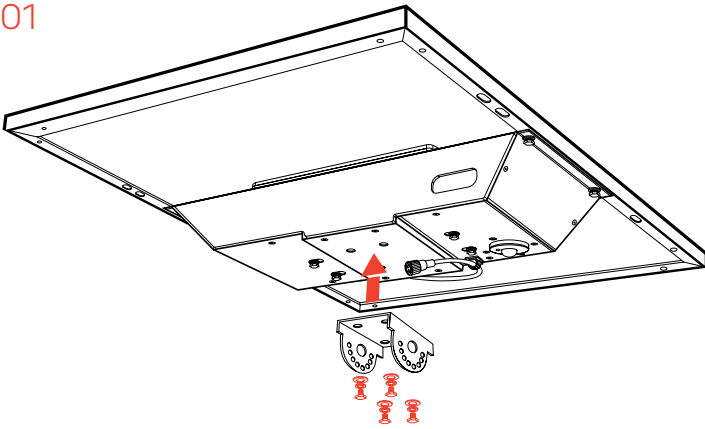

02

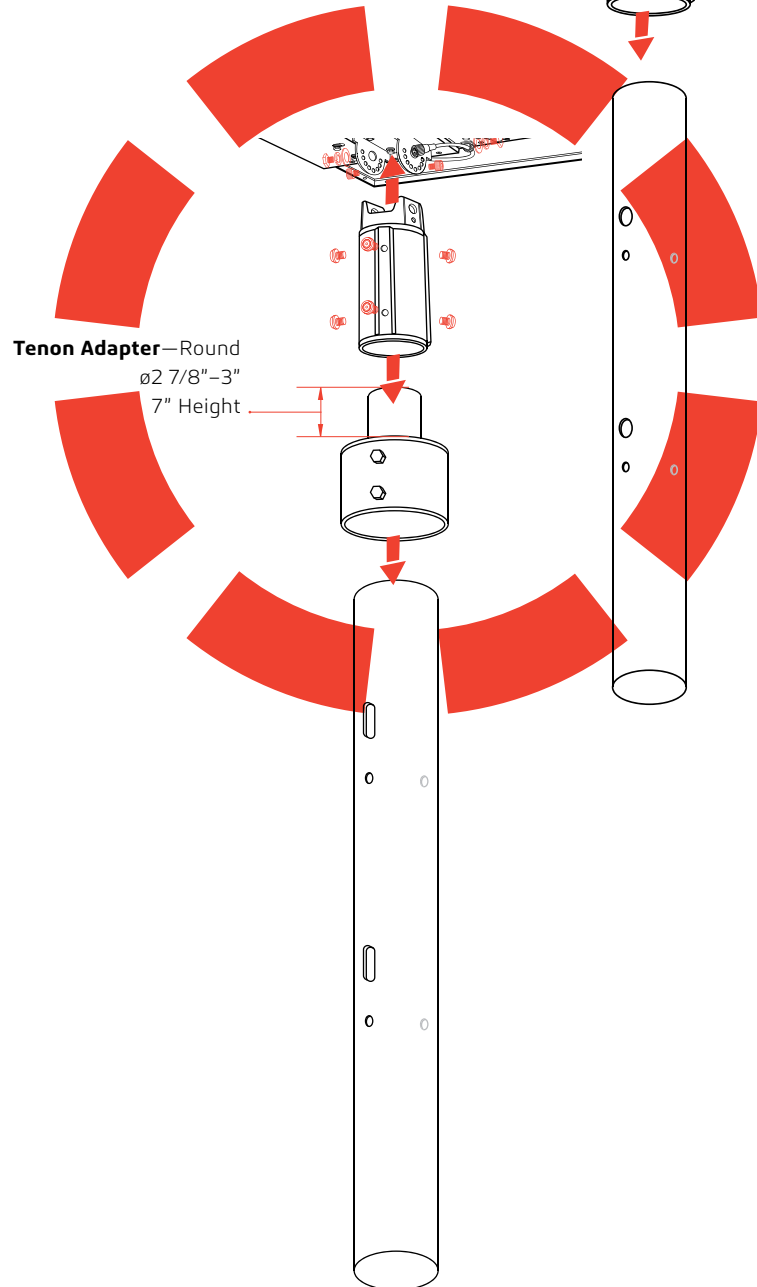
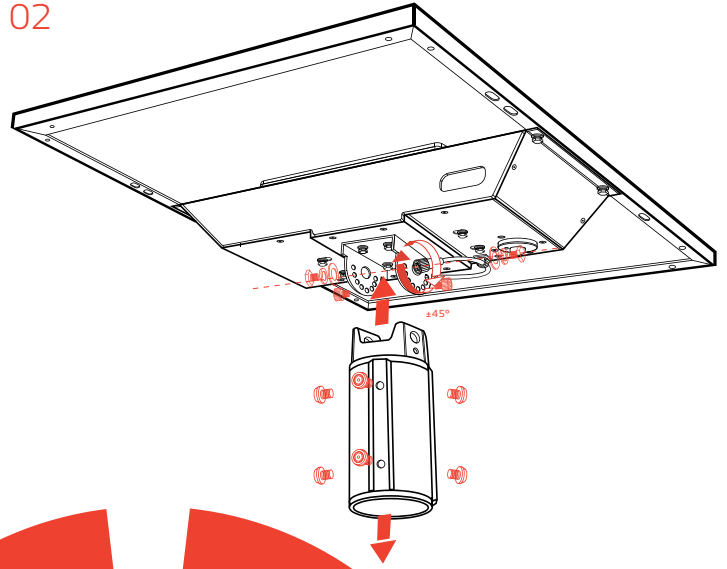

03

04

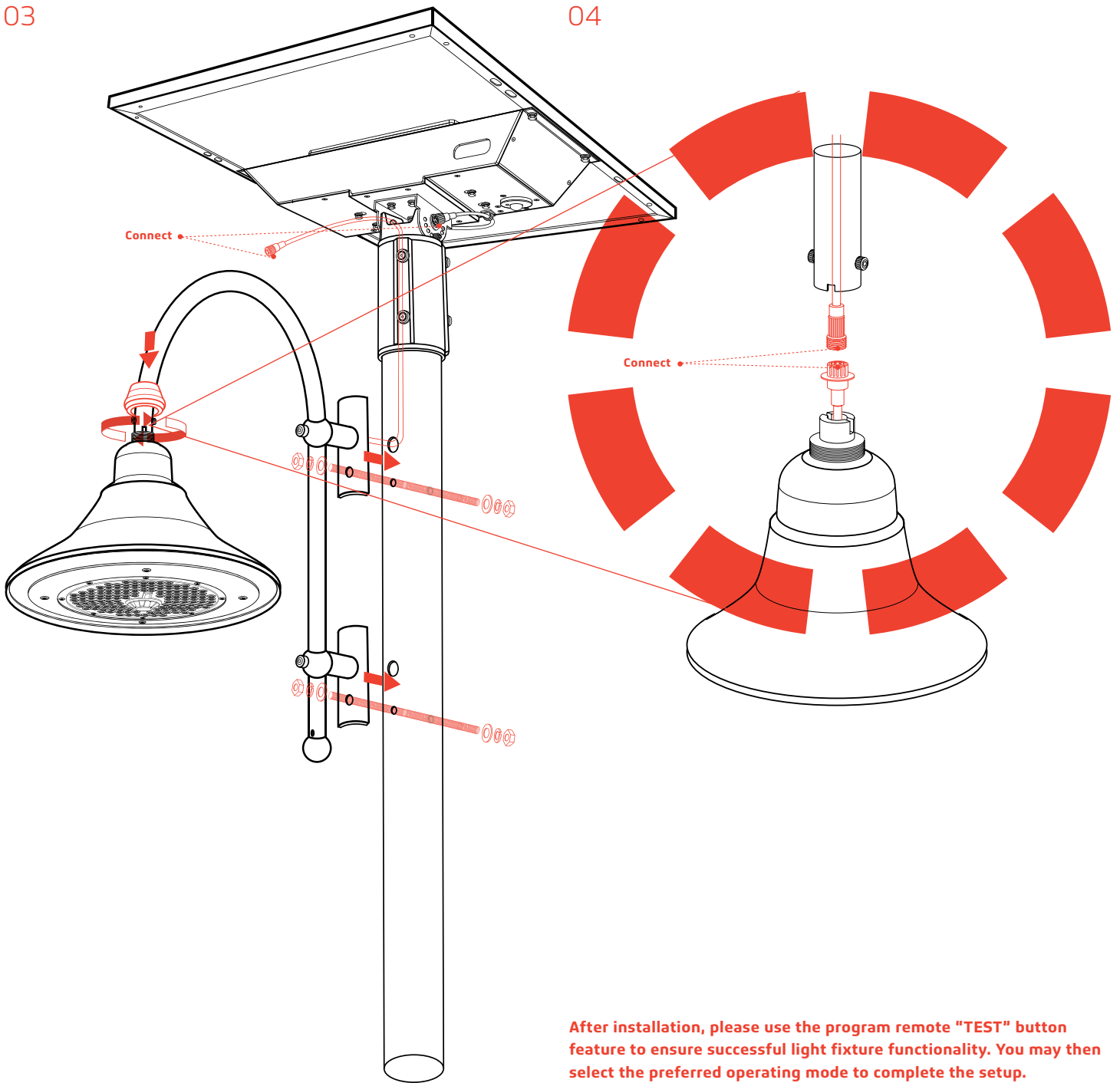

After installation, please use the program remote "TEST" button feature to ensure successful light fixture functionality. You may then select the preferred operating mode to complete the setup.

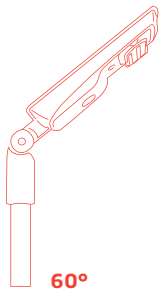

60°

70° N

69° N  
68° N  
67° N  
66° N

65° N

64° N  
63° N  
62° N  
61° N

60° N

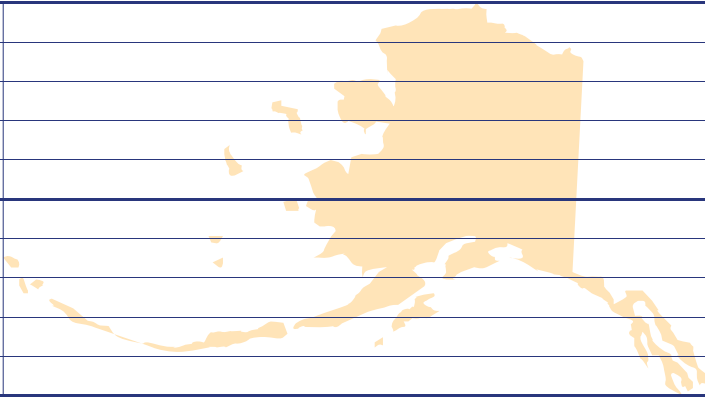

**Alaska**

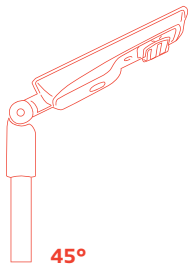

45°

49° N

48° N  
47° N  
46° N

45° N

44° N  
43° N  
42° N

41° N

40° N  
39° N  
38° N

37° N

36° N  
35° N  
34° N

33° N

32° N  
31° N  
30° N

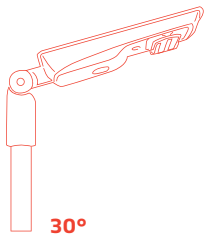
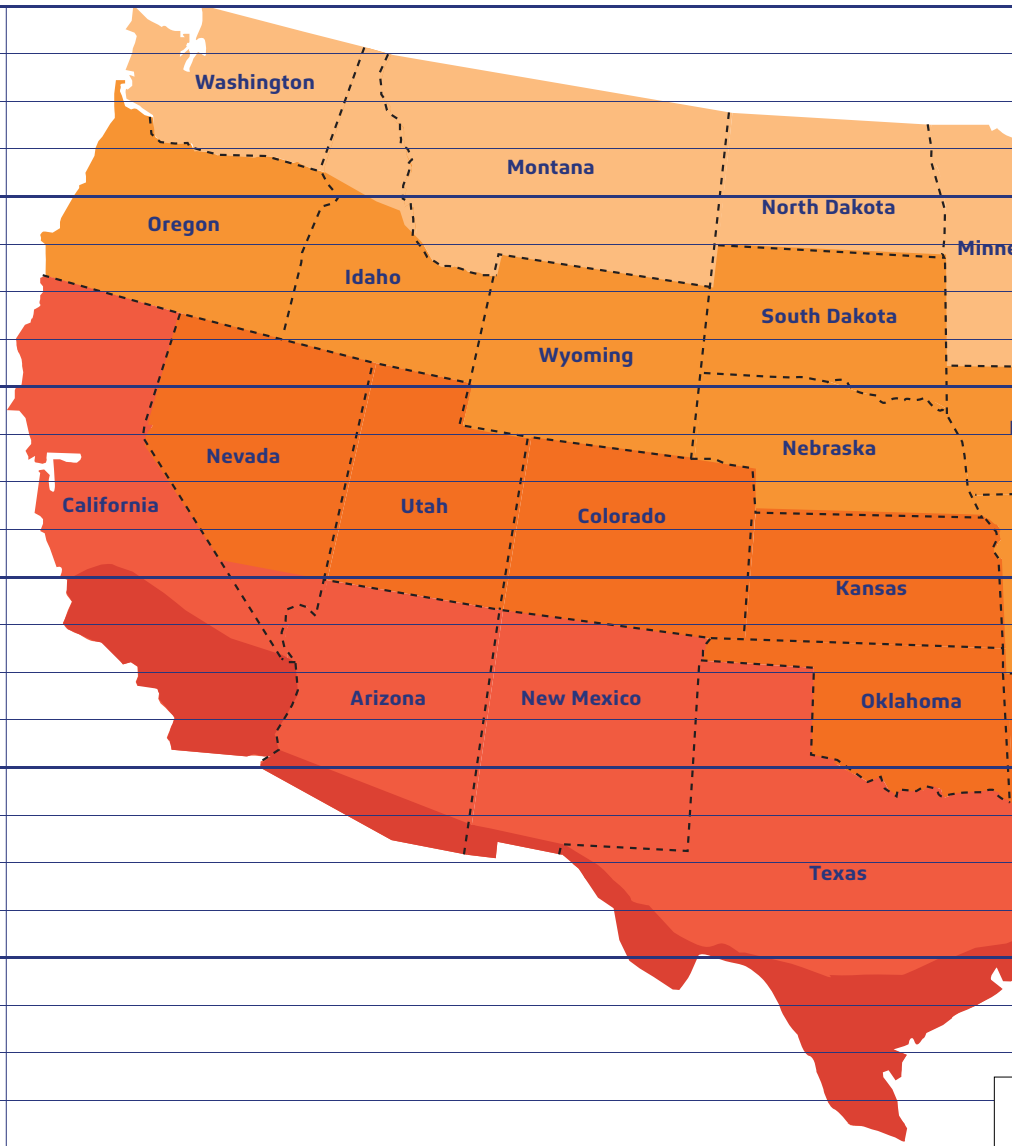

30°

29° N

28° N  
27° N  
26° N

25° N

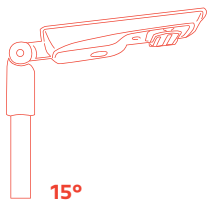

15°

21° N

20° N

19° N



**Hawaii**



# 06 Panel Angle

The solar charge in a battery pack won't last forever. The off-grid system relies on stored solar energy for autonomy. Angling your solar panels properly can boost the power intake of your solar lighting system. You want to angle your solar panels at a tilt based on the area's latitude.

## Tip

You can increase the tilt 15° in the winter or decrease 15° in the summer. In this way you can get the maximum sunlight to recharge the battery

## Key



## Best Facing Direction of Solar Panel

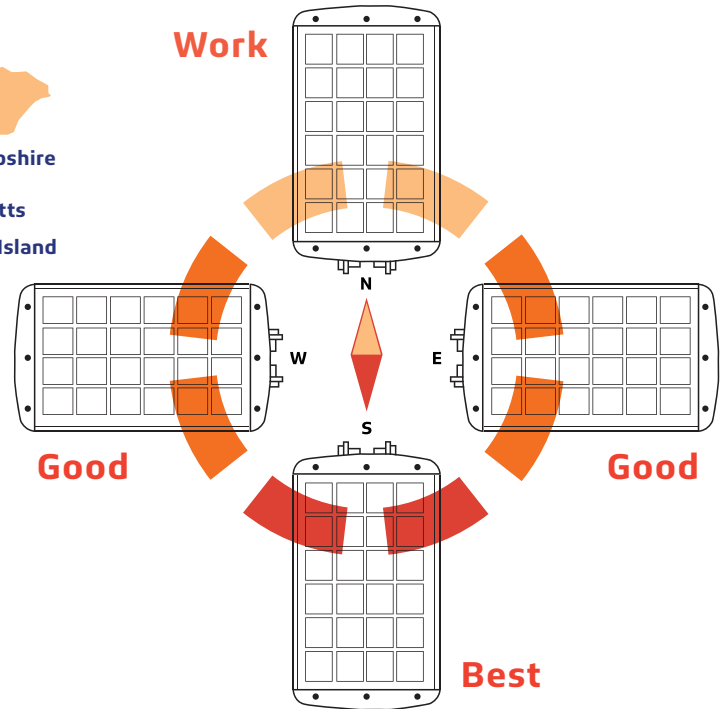

The area will dictate the installation of the fixtures and will sometimes prevent the lights from facing south. But that's okay! Panels facing West & East won't get as much light as Southern facing panels, but will still collect a good amount of sunlight. A North facing panel also works, but it will take longer to charge than any other direction. This would mean that the solar charge will be less optimal if installations are facing North.

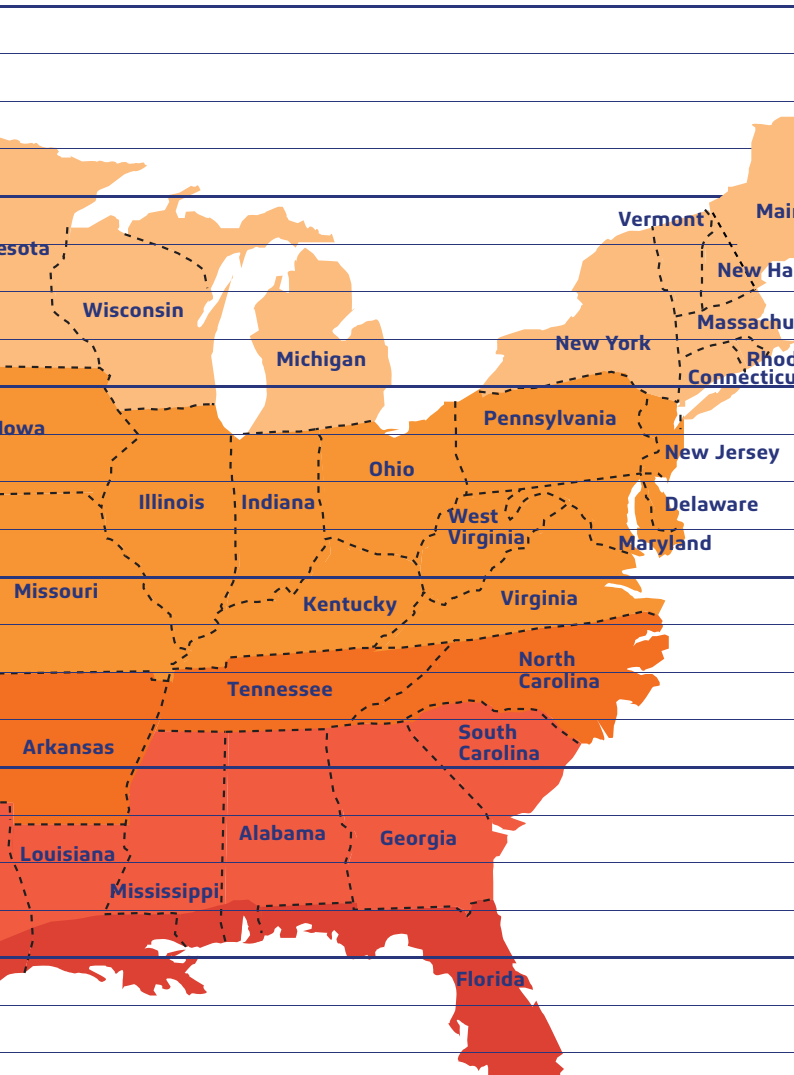

## World Wide Panel Angles

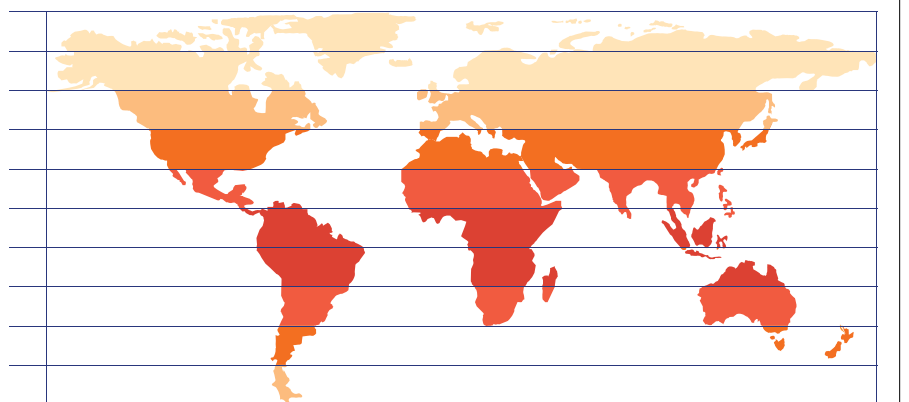
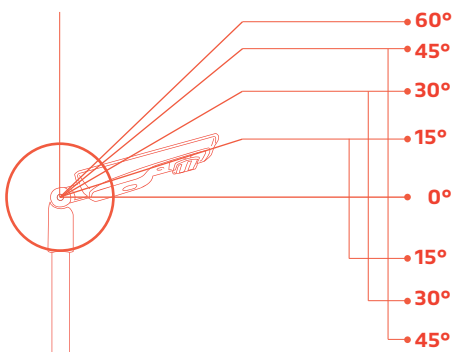

# 07 Remote Control Guide

**1. On/Off**

**2. Connect/Test**

**3. 40%~100% Motion Sensor Mode**

**4. 20%~80% Motion Sensor Mode (Default)**

**5. Night Owl Mode**

**6. Early Bird Mode**

**7. 100% Constant Mode**

**8. 70% Constant Mode**

**9. 40% Constant Mode**

**10. Timer Mode Disabled**

**11. Timer Mode 4 Hours**

**12. Time Mode 8 Hours**

Scan QR code to access Remote Control Guide Video.

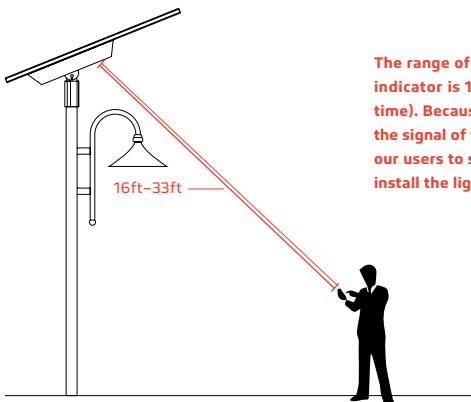

The range of the remote control to the indicator is 16ft (Day time) to 33ft (Night time). Because the sunlight will impact the signal of the remote control, we suggest our users to setup the mode before they install the light.

## 1. On/Off

When off is selected, the light will stop working. The solar panel will not charge the battery and the battery will not supply electricity to the light.

## 2. Connect/Test

Remote control device can be connected with any lighting fixture, one at a time. To connect, press the button once. It also functions as a test button. To test, press the "Test" button once, the red light will indicate the fixture is charging, green light indicates that the fixture is operating. Testing lasts for 10 seconds, and then it goes back to the mode previously in use.

### 3. 40%-100% Motion Sensor Mode

Constant 40% brightness (turns on at dusk, turns off at dawn); 100% brightness turns on for 2 minutes when motion is detected.

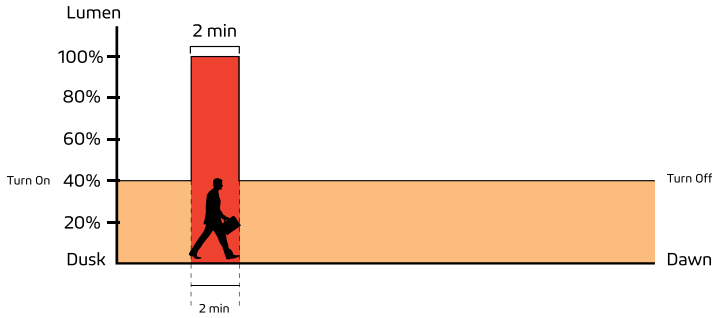

### 4. 20%-80% Motion Sensor Mode (Default)

Constant 20% brightness (turns on at dusk, turns off at dawn); 80% brightness turns on for 2 minutes when motion is detected.

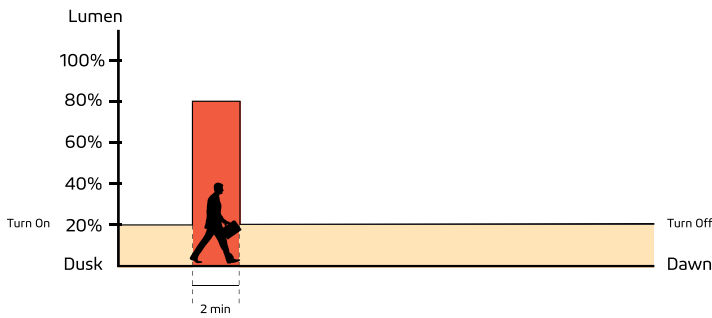

### (IAP) Intelligent Adaptive Program Battery Control Technology

In order to extend the off-grid autonomy of the ORINDA under shady trees, heavy rain, and thick clouds, our controllers now integrate an adaptive smart control feature to actively track battery capacity and adjust light output accordingly. Before integrating this feature, selecting a light output percentage on the remote would yield an accurate percentage of max LED brightness. Now with (IAP), the controller actively monitors the battery and regulates the electrical current to the LEDs. The controller makes light output of the selected percentage on the remote relative to battery capacity rather than max LED output. This smart-control feature can increase our off-grid performance by up to 40%.

### 5. Night Owl Mode

Changes as natural light decreases/increases (turns on at dusk); 70% brightness for 0.5 hour, 100% brightness for 3.5 hours, 70% brightness for 1 hour, 50% brightness for 1 hour, 20% brightness for 5 hours (turns off at Dawn).

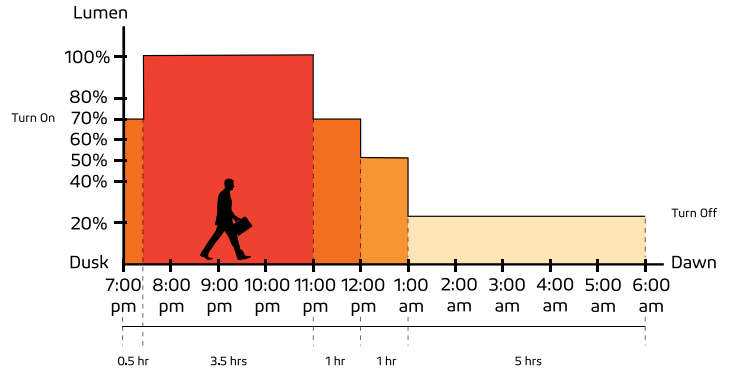

### 6. Early Bird Mode

Changes as natural light decreases/increases with increased brightness near dawn for early risers (turns on at dusk); 70% brightness for 0.5 hour, 100% brightness for 3.5 hours, 70% brightness for 1 hour, 50% brightness for 1 hour, 20% brightness for 4 hours, 100% brightness for 1 hour (turns off at Dawn).

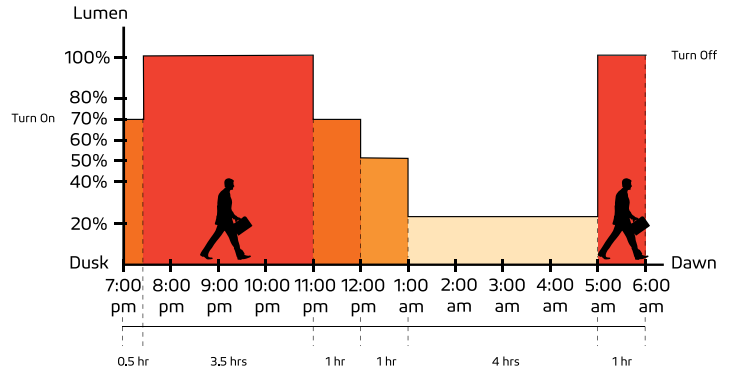

### Important

Dusk and dawn time can vary for different locations and seasons. The sensors in our products will monitor the light levels where it is installed. The time period shown in the chart above is just an example to help you understand the different lighting modes.

# 07 Remote Control Guide

## 7. 100% Constant Mode

100% brightness from dusk to dawn.

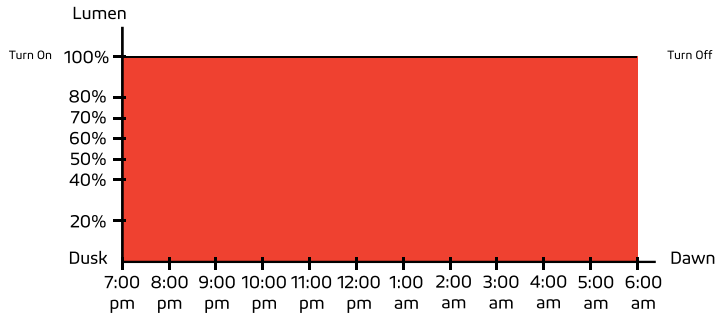

## 8. 70% Constant Mode

70% brightness from dusk to dawn.

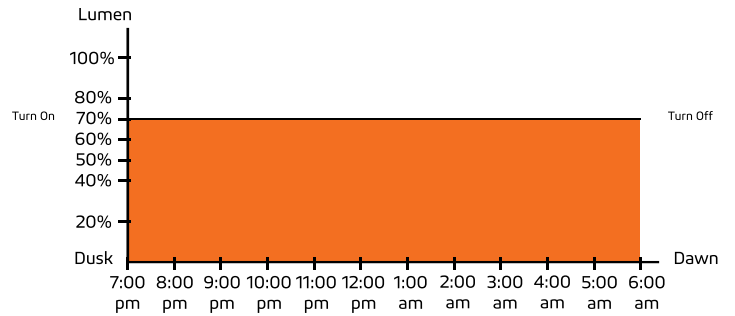

## 9. 40% Constant Mode

40% brightness from dusk to dawn.

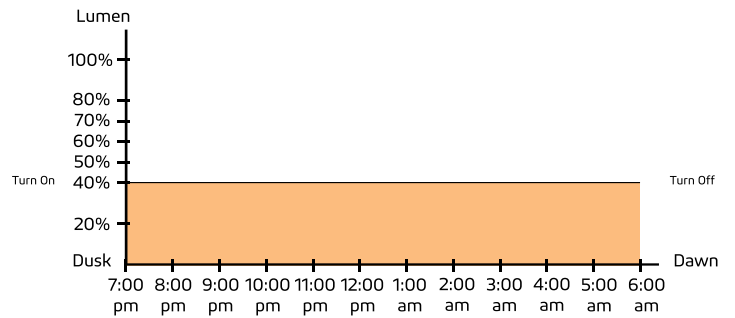

## 10. Timer Mode Disabled

Press this button to turn off Timer Mode; settings revert back to before Timer Mode was last activated.

### 11. Timer Mode 4 Hours

This is an additional mode which can work with any other modes. For example: press this button at any time after you turn on 70% Constant Mode. If the light turns on at 7pm at dusk, it will turn off at 11pm. It will repeat the same schedule hereafter until it is canceled by pressing Timer Mode Disabled.

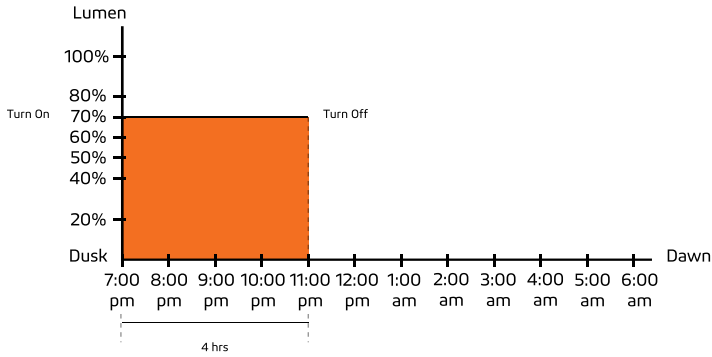

### 12. Time Mode 8 Hours

This is an additional mode which can work with any other modes. For example: press this button at any time after you turn on 70% Constant Mode. If the light turns on at 7pm at dusk, it will turn off at 3am. It will repeat the same schedule hereafter until it is canceled by pressing Timer Mode Disabled.

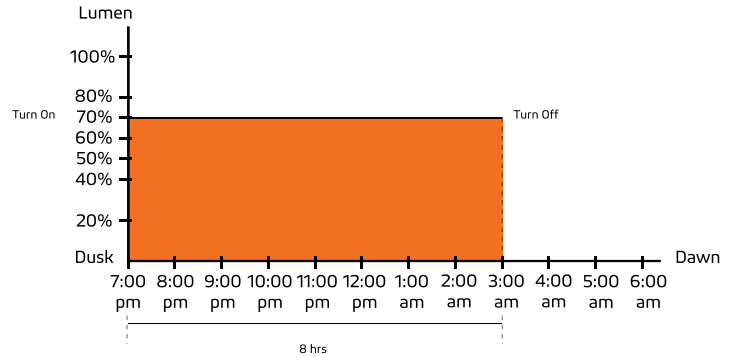

### Important

Dusk and dawn time can vary for different locations and seasons. The sensors in our products will monitor the light levels where it is installed. The time period shown in the chart above is just an example to help you understand the different lighting modes.

**ORINDA products are covered by a 5 year limited warranty. SOLTECH urban light warrants to the original purchaser that this product is free from defects in materials and workmanship for the period of 5 years from date of purchase. To obtain warranty service please contact your local distributor or sales rep for further instruction.**



---

1460 Park Avenue.  
Emeryville, CA 94608 USA

[www.soltechlighting.com](http://www.soltechlighting.com)

*SOLTECH LLC reserves the right to update all product data sheets at any time. Consult SOLTECH marketing specialists for publication updates at [hello@soltechlighting.com](mailto:hello@soltechlighting.com)*

*Copyright©2023-2024 SOLTECH LLC,  
All Rights Reserved.*



**SOLTECH Designs  
and Manufactures  
Advanced,  
Solar-Powered  
LED Technology.**