

CATALOG		COMMENTS
PROJECT		
PREPARED BY		
DATE		



RICHMOND Solar Bus Stop Light 8W/16W

[DUSK TO DAWN ILLUMINATION]

[EASY AND FAST INSTALLATION]

[ATTACH UP TO TWO LED LUMINAIRES]

[ADJUSTABLE LED PLACEMENT WHERE YOU NEED IT]



APPLICATIONS

Waiting at a bus stop at dusk or in the dark can sometimes be an unnerving experience. When connection to the electric grid isn't available, a solution to this problem is our RICHMOND Solar Bus Stop Light.

It provides a safe and eco-friendly way to ensure citizens and visitors feel secure in outdoor transit queuing areas while waiting for transportation.

DESCRIPTION

RICHMOND Solar Bus Stop Light includes automatic dusk to dawn photocell sensor, it's easy and inexpensive to provide light. Each unit comes with up to two Super Bright LED luminaires. Delivers up to 38 hours of illumination when fully charged.



RICHMOND Solar Bus Stop Light 8W/16W

CATALOG		COMMENTS
PROJECT		
PREPARED BY		
DATE		

FEATURES



Low Maintenance & Smart Design

- All-in-One Design: Solar panel, battery & controller in one Luminaire
- Die cast A380 aluminum fixture housing is rust-free
- Low EPA requirement
- Dusk to dawn illumination
- Up to 2 luminaires to provide security lighting exactly where you need it



Longer Life

- Grade A LifePO4 Battery Pack, 2000+ full charging cycles
- Lumileds 5050 LED chips



High Brightness, Smart Power Consumption

- 190lm/W—the highest efficiency in the industry
- Smart MPPT Controller
- Up to 38 Hours (3 nights) on full charge

PRODUCT SIZE

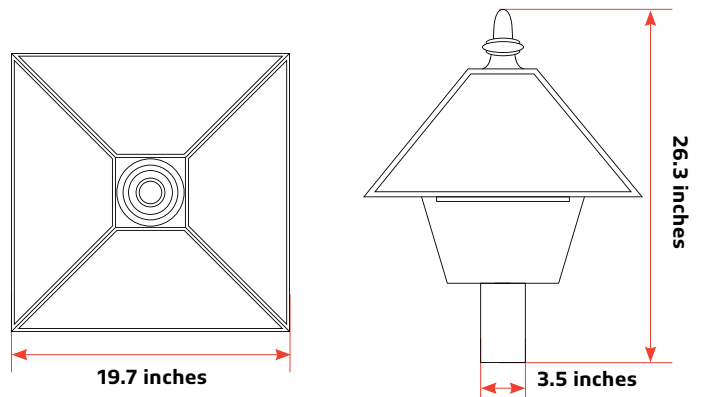

- Mono-Crystalline Solar Panel (X4)

- LIFEPO₄ Battery
- MPPT smart controller

- Fixture Slip Fit Secured with 2 Stainless Steel Through Bolts

- Adjustable LED placement to provide security lighting exactly where you need it. Attach up to two led modules

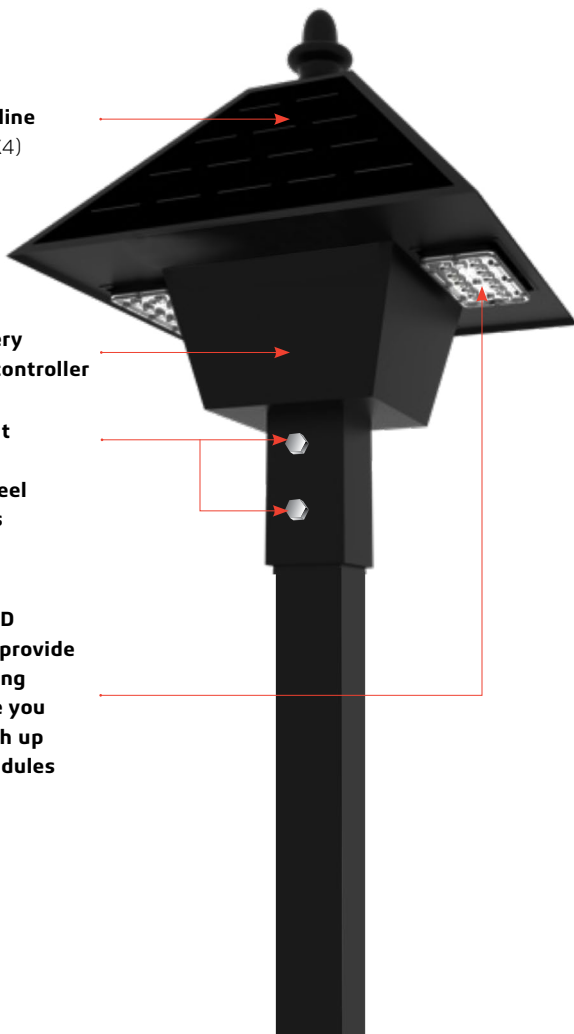

- Up to 2 luminaires to provide security lighting exactly where you need it (only center position shown)
- The Led Luminaire is adjustable from -6° to +15°

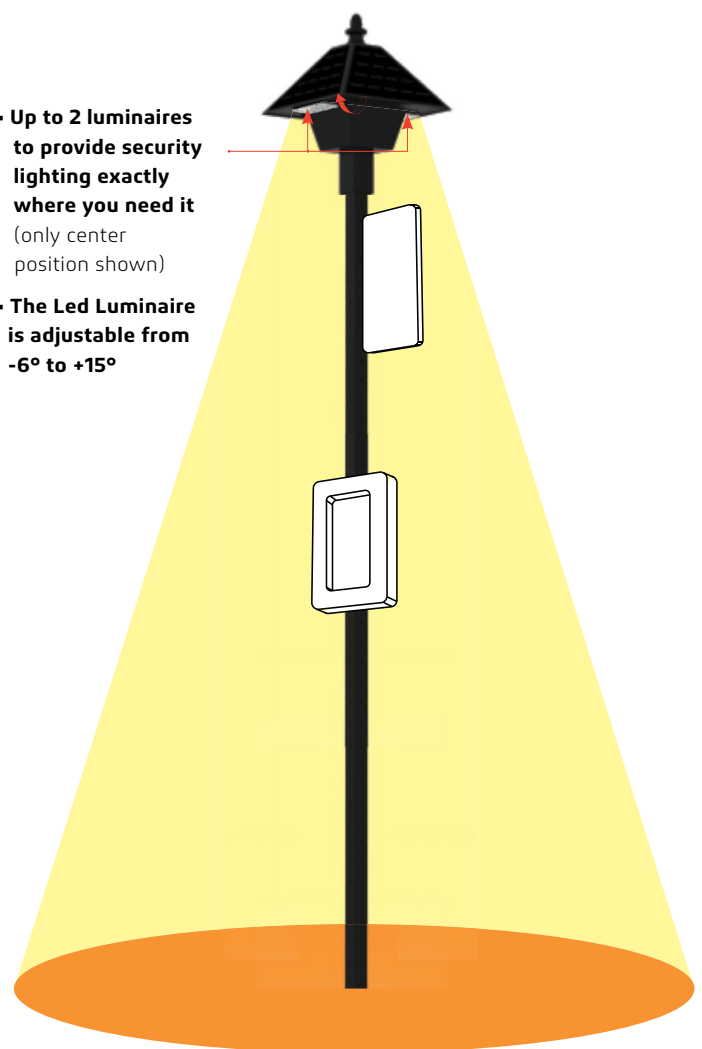



RICHMOND Solar Bus Stop Light 8W/16W

CATALOG		COMMENTS
PROJECT		
PREPARED BY		
DATE		

PRODUCT SPECIFICATIONS

LED Nominal Power: 8W / 16W

Solar Panel: Mono-Crystalline 18V 50W

Battery: 12.8V 12AH

CCT: 3,000K/ 4,000K/ 5,000K/ 5,700K/ 6,500K

Lumen Output: 1,520LM / 3,040LM

IP Rating: IP65

* **Charging Time:** 9hrs@(1000W/m²)

* **Run Time (@Full Power):** 38hrs

* **Operating Temperature:** -30°C/-22°F to 140°F

* **Charging Temperature:** -30°C/-22°F to 140°F

*The temperature can impact the battery's charging and normal operation.

*The solar charge time data is base on 77 degree F ambient temperature with the panel pointed directly at the solar radiatio
The standard radiation value is 1000W/m².

MPPT CONTROLLER

- Maximum Power Point Tracking (MPPT) is a technique for tracking and regulating the output energy from the solar panel to the battery.
- Measures the solar panel output voltage and current in real-time and continuously tracks the maximum power.
- Regulates the output voltage so that the system can always charge the battery with the maximum power.
- Significantly improves the solar system energy utilization rate, with a conversion efficiency up to 97%.
- Increases the solar system's charging efficiency by at least 20% compared to Pulse Width Modulation (PWM)

ORDERING INFORMATION

SERIES	WATTAGE	COLOR TEMPERATURE	FINISH
STL-RMD =RICHMOND	08=8W 1,520 Lumens 16=16W 3,040 Lumens	3=3000K	WH=White GY=Gray BK=Black
		4=4000K	
		5=5000K	
		6=5,700K	
		7=6,500K	

- - -

Example: STL-RMD163BK

This example product number is for RICHMOND 16 watt, 3000K CCT, with a black finish.



RICHMOND Solar Bus Stop Light 8W/16W

MORAGA is covered by a 5 year limited warranty. SOLTECH urban light warrants to the original purchaser that this product is free from defects in materials and workmanship for the period of 5 years from date of purchase. To obtain warranty service please contact your local distributor or sales rep for further instruction.

CATALOG		COMMENTS
PROJECT		
PREPARED BY		
DATE		



1460 Park Avenue.
Emeryville, CA 94608 USA

soltechlighting.com

SOLTECH LLC reserves the right to update all product data sheets at any time. Consult SOLTECH marketing specialists for publication updates at hello@soltechlighting.com

*Copyright©2018-2024 SOLTECH LLC,
All Rights Reserved.*