



# HYBRID

45W 65W

## Installation Manual

SOLTECH Designs and Manufactures  
Advanced, Solar-Powered  
LED Technology.



# Contents

---

01 Introduction	03
02 Battery Notes	04
03 Installation and Wiring Compliance	04
04 Mounting Accessories	05
05 Installation	06
06 Panel Angle	08
07 Detection Zone	010
08 Remote Control Guide	011

## HYBRID 45W

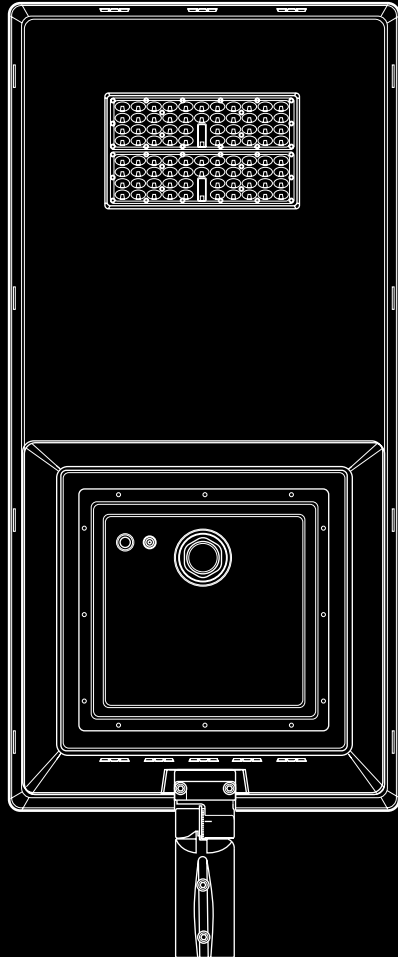

## HYBRID 65W

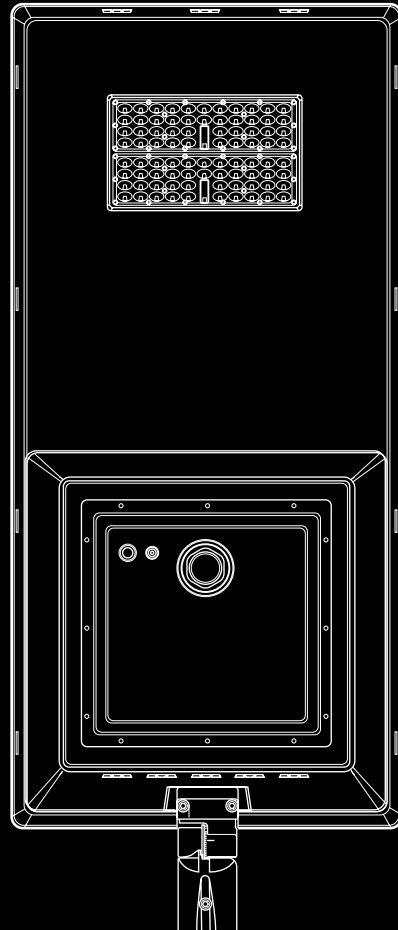

# 01 Introduction

Thank you for purchasing HYBRID Urban Lighting Products.

## Introduction

Outdoor solar lighting systems use solar cells which convert sunlight into electricity. Electricity is stored in batteries for use at night. HYBRID solar lights are easy to install and virtually maintenance free. Using them won't increase your electric bill.

## Important

In order to avoid deep discharge of the battery during storage, please fully recharge your battery every 4 months. Please make sure that the light is installed in an area with sufficient sunlight irradiance. A strict minimum of 3.5 hours/day of sunshine on average is recommended. Select the right operating mode according to the local legislation needs and the local sunshine conditions. Keep it away from shadows. Self-cleaning available when the light fixture have minimum angle of 15 degrees.

Please save these instructions. Read all of the instructions carefully before attempting to carry out any installation or wiring. Do not open or

attempt to repair the product on your own, as it may cause serious damage and would void the product warranty. Contact your local distributor for any questions concerning the installation.

Range of the light module on the lighting fixture is 20–26 feet (6–8 meters). The ideal installation spacing is >16 feet (5 meters). When installing two or more lighting fixtures on one pole, select desired operating mode before installation. Interference can cause delay or malfunction when using the remote control to change operating modes after installation.

## Precautions when working with solar panels

When the solar panel is exposed to sunlight, a voltage appears at the output terminals of the solar panel turning it into a source of electricity. To avoid a shock hazard, make sure the solar panel is covered with an opaque (dark) later such as paper or cloth during the installation. Do not make contact with the terminals when the panel is exposed to sunlight or any other light source.

## HYBRID 45W

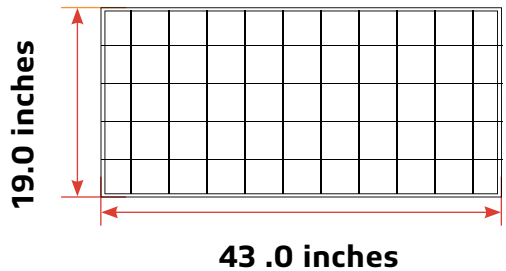
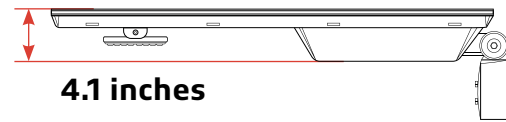
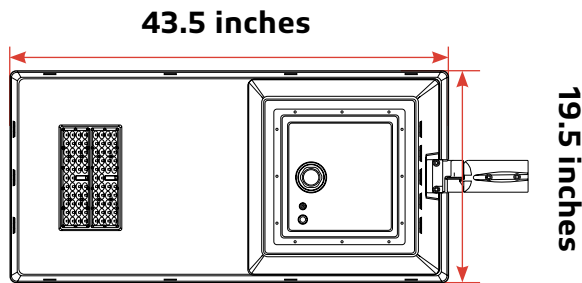

## HYBRID 65W

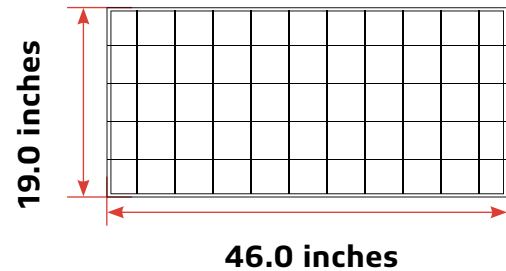
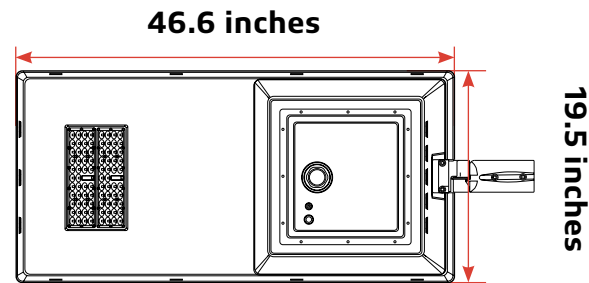

# 02 Battery Notes

1. The  $\text{LiFePO}_4$  -battery-powered Sunlike lights are visibly brighter than other outdoor solar lights, and their performance overall is more reliable.
2. To charge the battery fully may take up 6 to 12 hours.
3. The rechargeable battery can work continuously for 10 hours at full power.
4. Output will be reduced to 40% when the battery is below 40% of its capacity.
5. Battery will stop charging when the ambient temperature is below  $-22^\circ\text{F}$  or above  $140^\circ\text{F}$ .

## (IAP) Intelligent Adaptive Program Battery Control Technology

In order to extend the off-grid autonomy of the HYBRID under shady trees, heavy rain, and thick clouds, our controllers now integrate an adaptive smart control feature to actively track battery capacity and adjust light output accordingly. Before integrating this feature, selecting a light output percentage on the remote would yield an accurate percentage of max LED brightness. Now with (IAP), the controller actively monitors the battery and regulates the electrical current to the LEDs. The controller makes light output of the selected percentage on the remote relative to battery capacity rather than max LED output. This smart-control feature can increase our off-grid performance by up to 40%.

**Battery Status is indicated by the red/green indicator on the lighting fixture as follows:**

### - Red indicator (Charging)

- > Slow red light flashing = Charging
- > Red light continuously on = fully charged
- > Quick red flashing = charge fault

### - Green indicator (Discharging)

- > Green light continuously on = more than 40% of the battery capacity remaining
- > Slow green light flashing = battery capacity below 10%
- > Quick green light flashing = battery below 0% mode—Protect battery does not over discharging



## Storage

To avoid over discharge of the battery during storage, please recharge the lighting fixture every 3 months. Use the dedicated charger to charge, reset the switch when done.

## MPPT Controller

- Maximum Power Point Tracking (MPPT) is a technique for tracking and regulating the output energy from the solar panel to the battery.
- Measures the solar panel output voltage and current in real-time and continuously tracks the maximum power.
- Regulates the output voltage so that the system can always charge the battery with the maximum power.
- Significantly improves the solar system energy utilization rate, with a conversion efficiency up to 97%.
- Increases the solar system's charging efficiency by at least 20% compared to Pulse Width Modulation (PWM)

# 03 Installation and Wiring Compliance

1. Installation and wiring must comply with the State and National Electrical Codes.
2. The HYBRID 45W/65W model is intended for outdoor use only and should not be installed in an unventilated area, and shall be installed in an environment within the operational temperatures defined for the product.
3. Before installation, if applicable, please ensure the light pole and its foundation are solid enough to withstand the lighting fixture(s).
4. Before installation, please ensure that the battery is fully charged. Install during sunny days if possible.
5. Before installation, please press the  ON/OFF key in the remote control and check whether it shows a red light on the indicator. Please cover the panel and check if the light module turns on normally within 1 minute.

## After Installation

The lighting fixture will automatically turn on at night and turn off during daylight.

## Important

Always orient the solar panel facing the equator (e.g. facing south if in northern hemisphere).

Always have a tilt angle of at least  $15^\circ$  to avoid dust accumulation ( $0^\circ$ =horizontal plane).

# 04 Mounting Accessories

## A. TRUNNION—Wall Mount

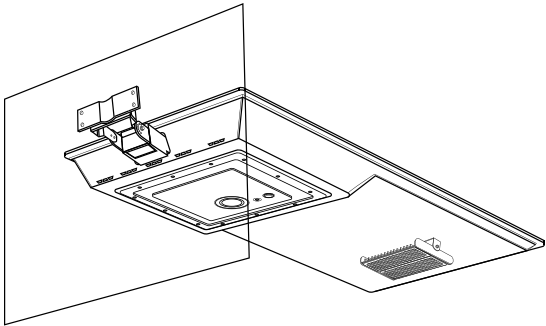

A-a. STLHYP-WM

## B. SLIP FITTER

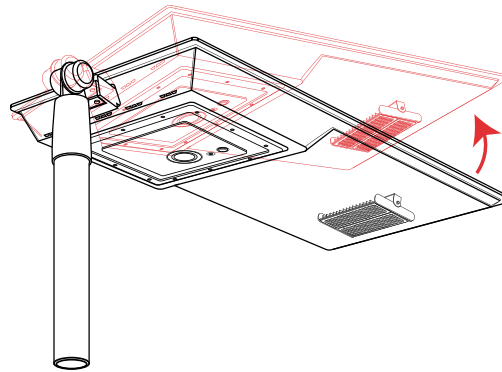

B-b. STLHYP-SF

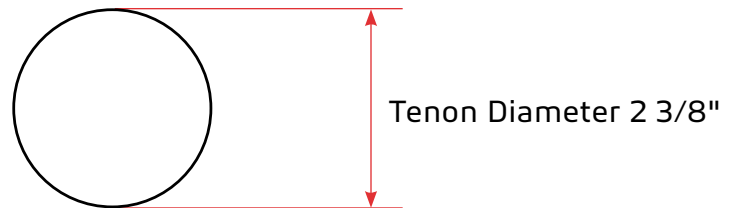

## C. TRUNNION—Round

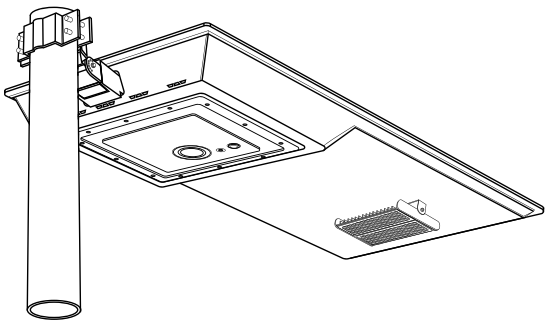

### Round Pole Diameter

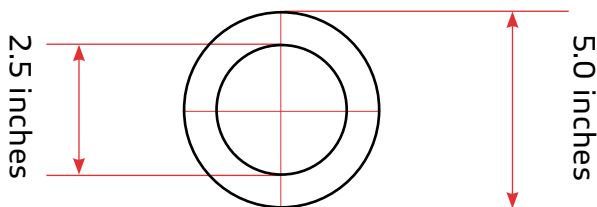

C-c. STLHYP-TR

## D. TRUNNION—Square

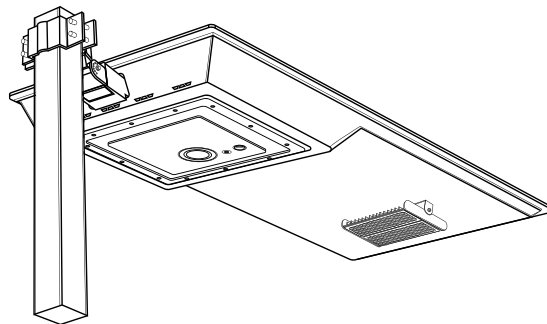

### Square Pole Dimension

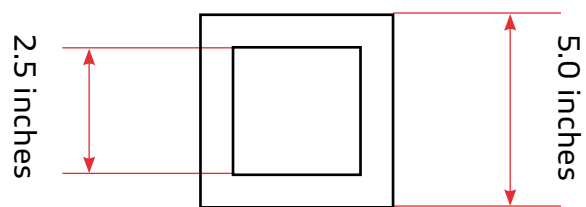

D-d. STLHYP-TR

# 05 Installation

## Trunnion Mount

01

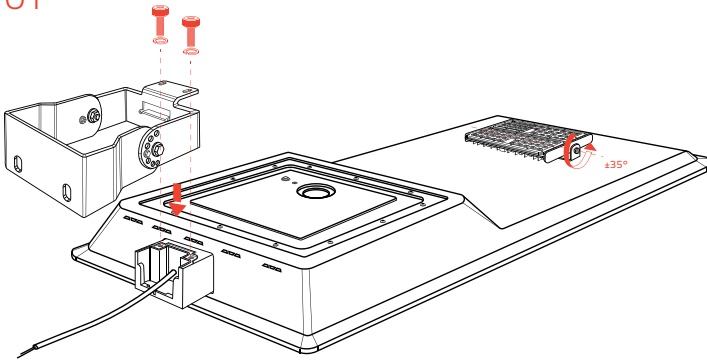

02

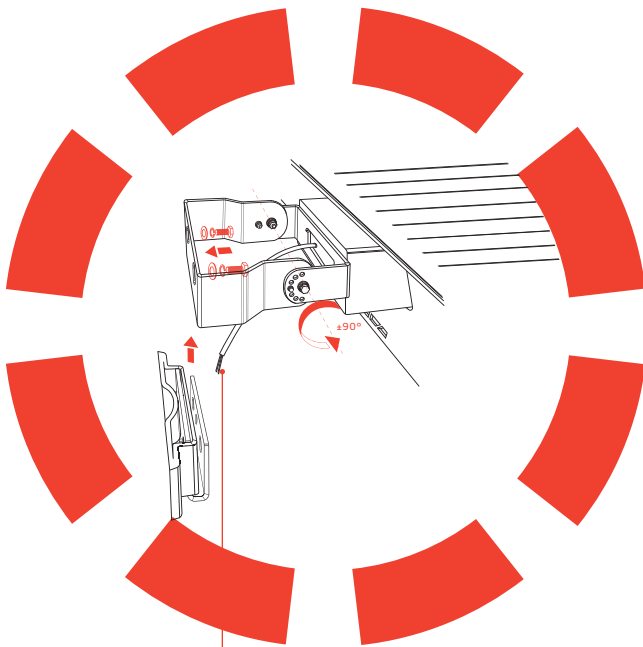

Connect cable with on-grid power.

**A. On Wall**

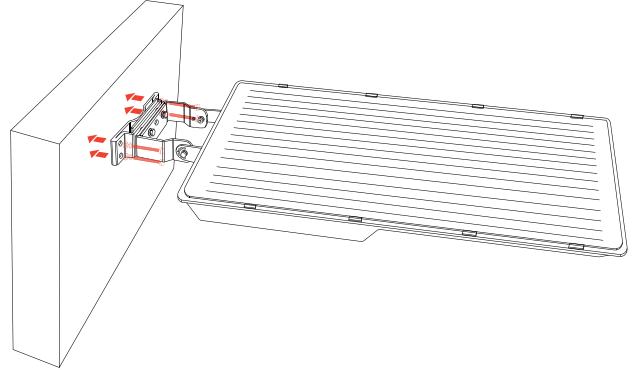

**B. On Round Pole**

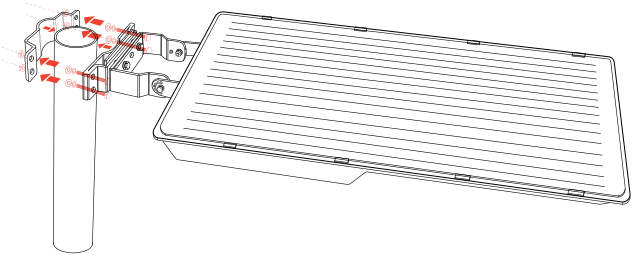

**C. On Square Pole**

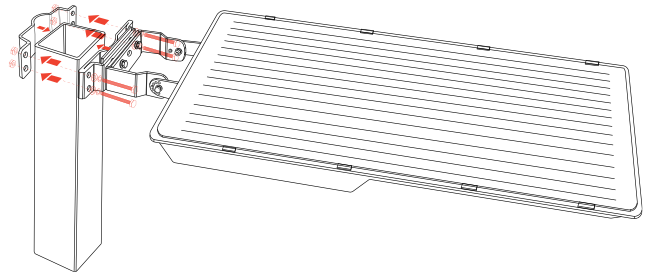



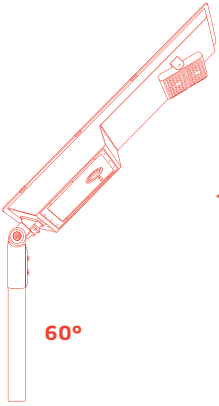

**Alaska**

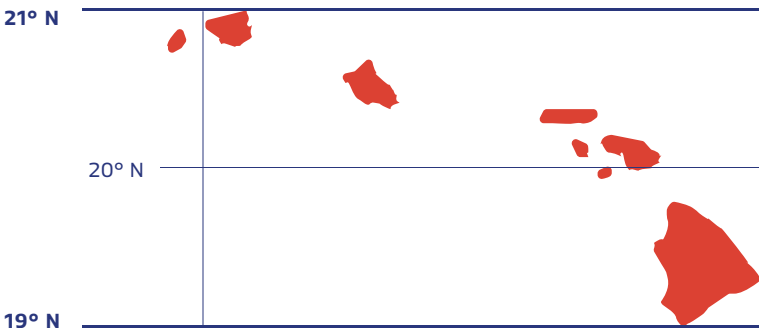
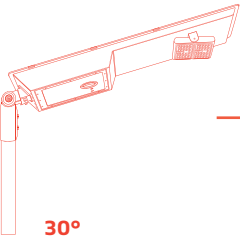
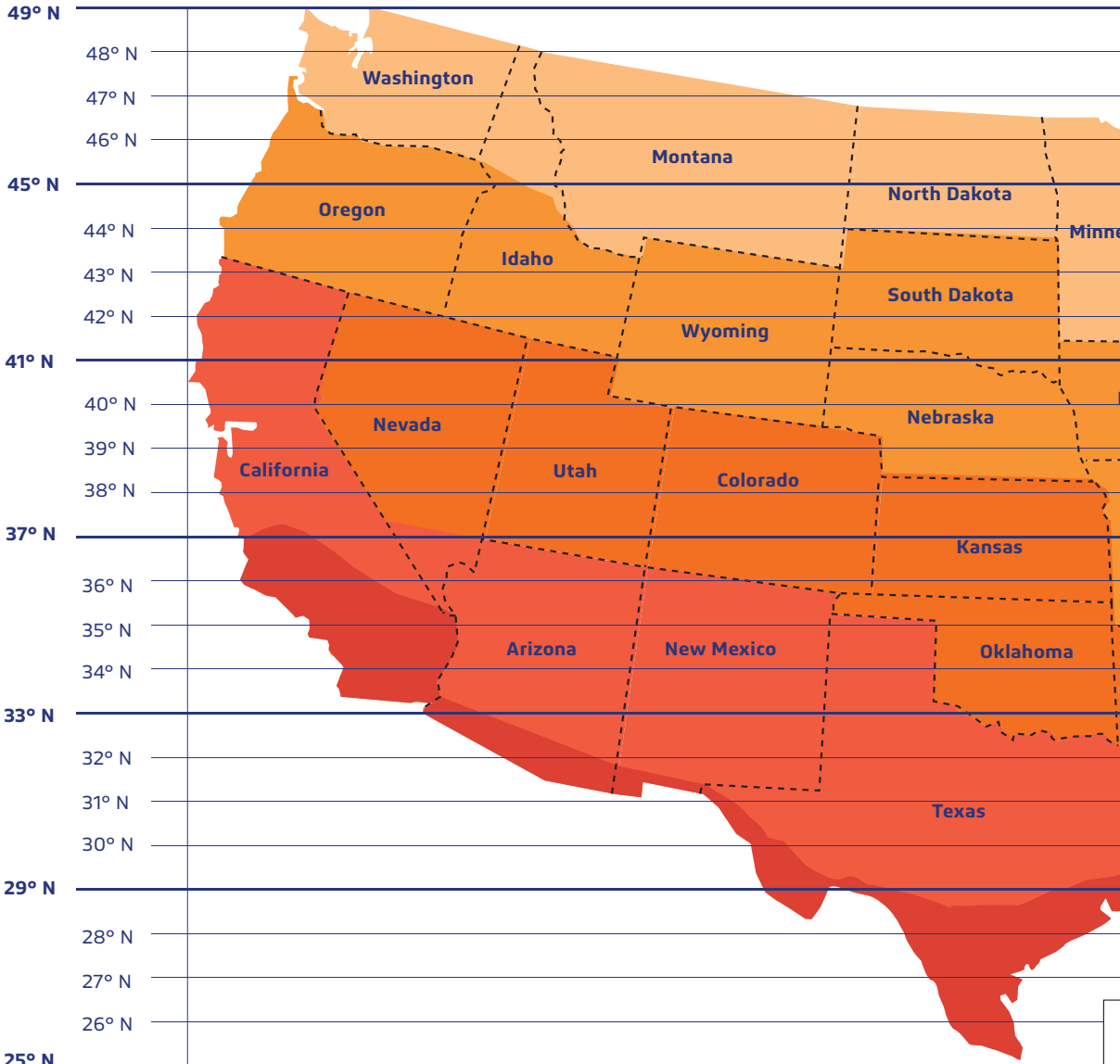
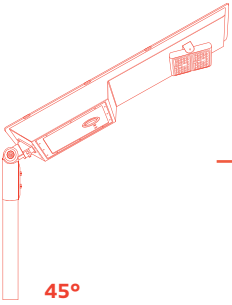

**Hawaii**



# 06 Panel Angle

The solar charge in a battery pack won't last forever. The off-grid system relies on stored solar energy for autonomy. Angling your solar panels properly can boost the power intake of your solar lighting system. You want to angle your solar panels at a tilt based on the area's latitude.

## Tip

You can increase the tilt 15° in the winter or decrease 15° in the summer. In this way you can get the maximum sunlight to recharge the battery

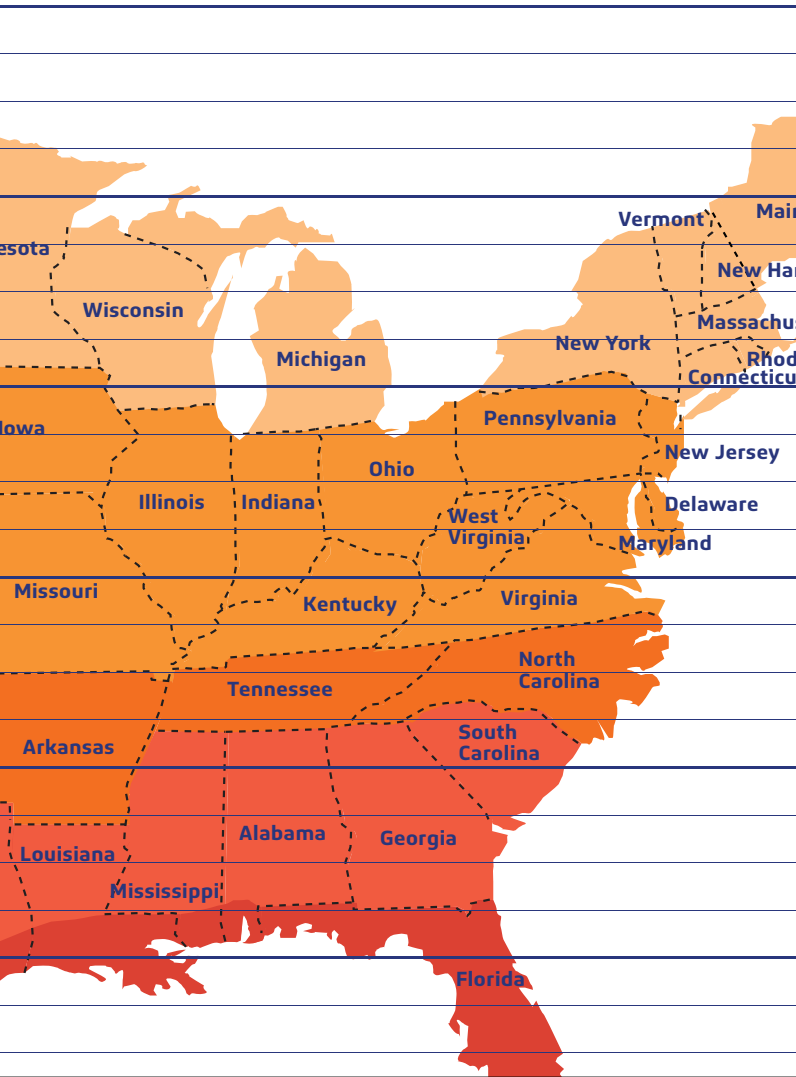

## Key



## Best Facing Direction of Solar Panel

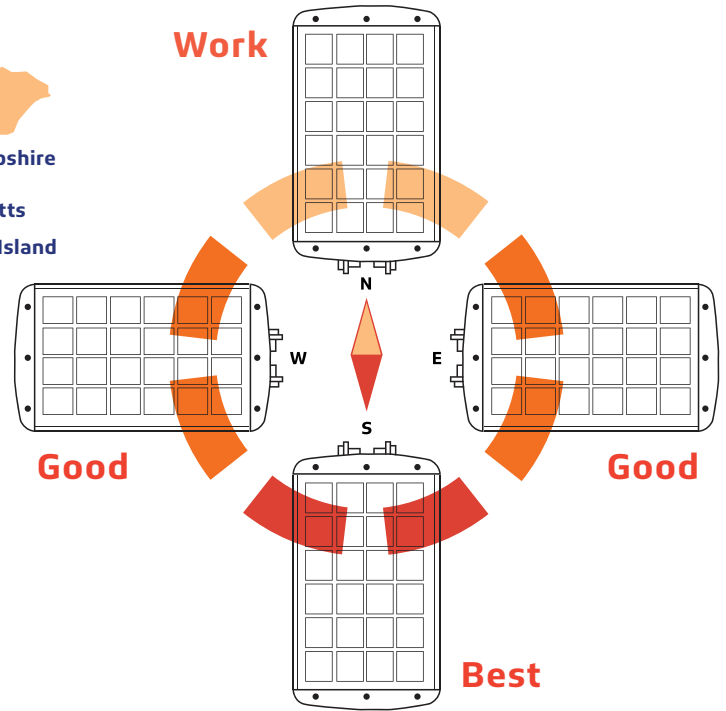

The area will dictate the installation of the fixtures and will sometimes prevent the lights from facing south. But that's okay! Panels facing West & East won't get as much light as Southern facing panels, but will still collect a good amount of sunlight. A North facing panel also works, but it will take longer to charge than any other direction. This would mean that the solar charge will be less optimal if installations are facing North.

## World Wide Panel Angles

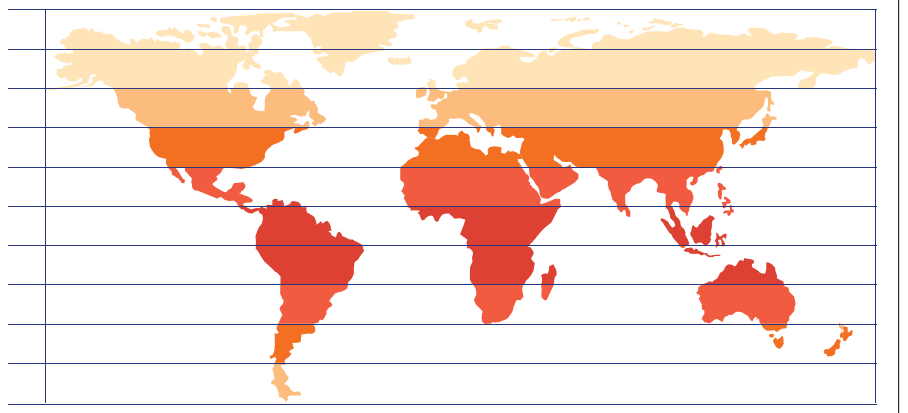
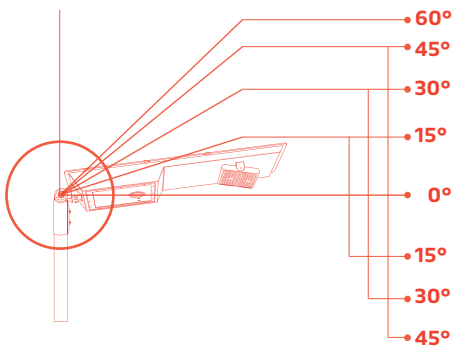

# 07 Detection Zone

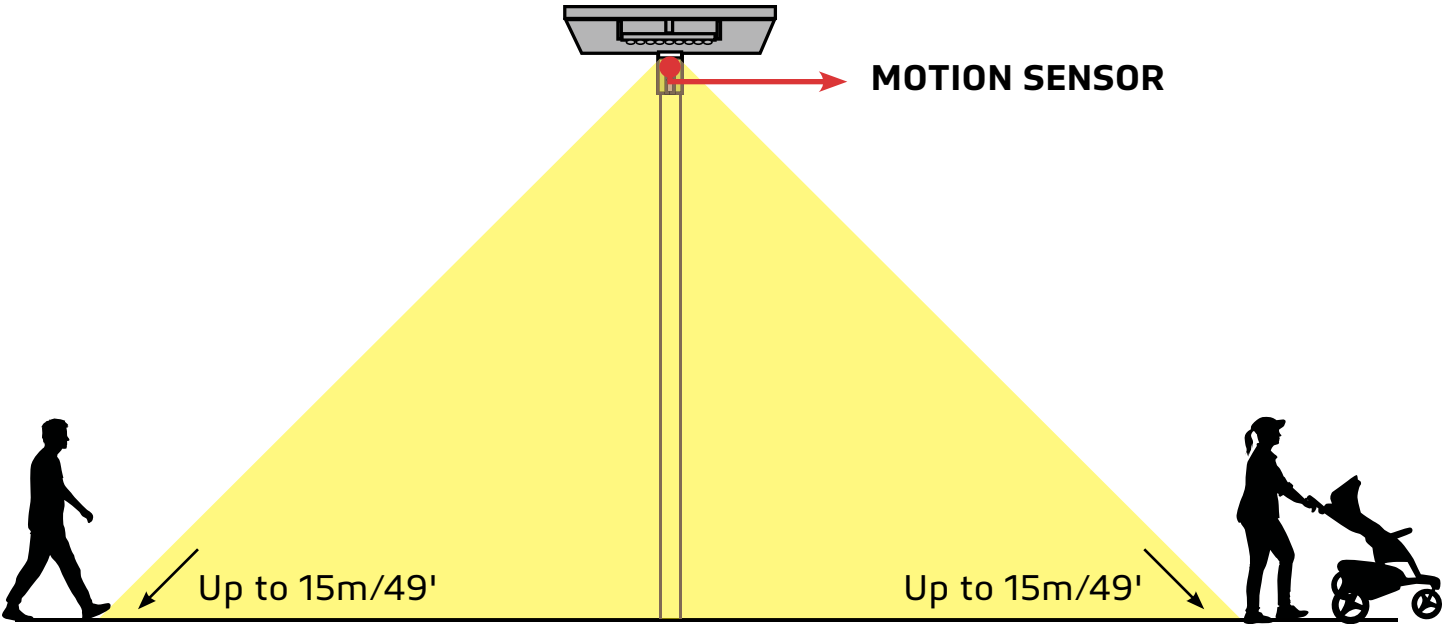

# 08 Remote Control Guide

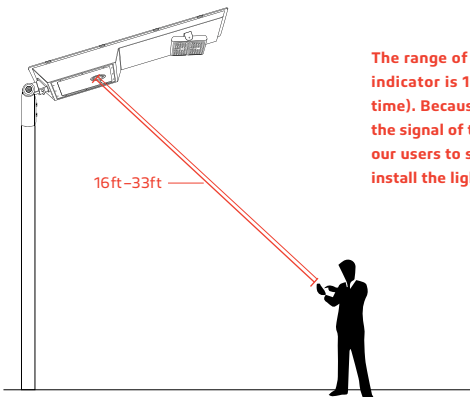
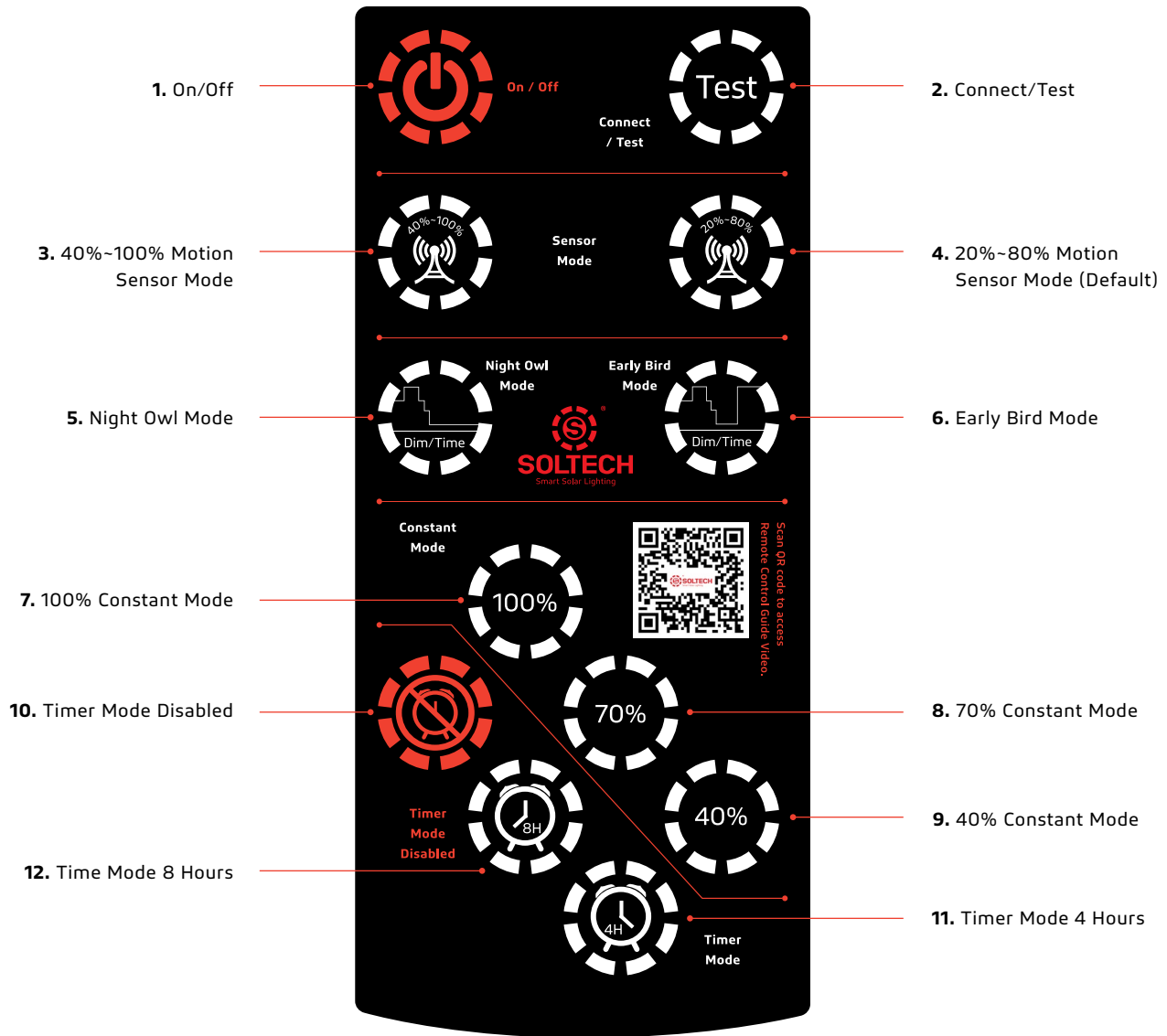

The range of the remote control to the indicator is 16ft (Day time) to 33ft (Night time). Because the sunlight will impact the signal of the remote control, we suggest our users to setup the mode before they install the light.

## 1. On/Off

When off is selected, the light will stop working. The solar panel will not charge the battery and the battery will not supply electricity to the light.

## 2. Connect/Test

Remote control device can be connected with any lighting fixture, one at a time. To connect, press the button once. It also functions as a test button. To test, press the "Test" button once, the red light will indicate the fixture is charging, green light indicates that the fixture is operating. Testing lasts for 10 seconds, and then it goes back to the mode previously in use.

# 08 Remote Control Guide

## 3. 40%-100% Motion Sensor Mode

Constant 40% brightness (turns on at dusk, turns off at dawn); 100% brightness turns on for 2 minutes when motion is detected.

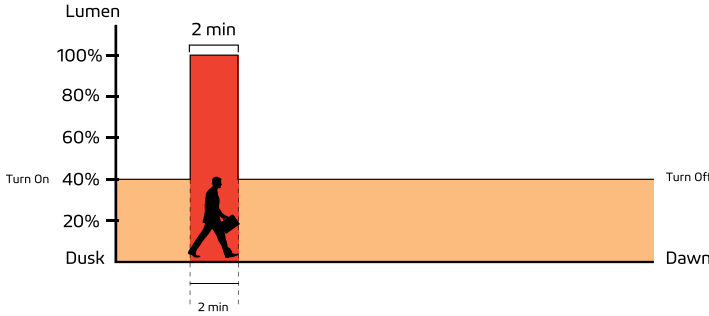

## 4. 20%-80% Motion Sensor Mode (Default)

Constant 20% brightness (turns on at dusk, turns off at dawn); 80% brightness turns on for 2 minutes when motion is detected.

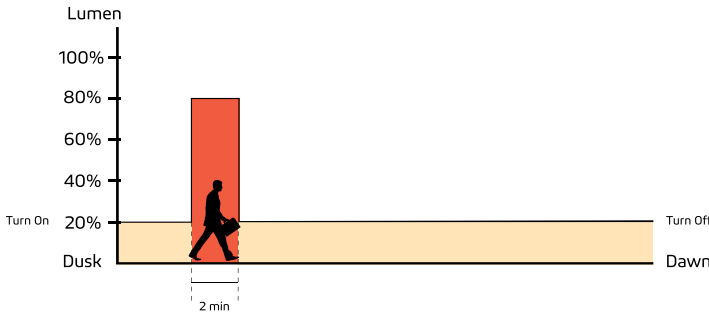

## (IAP) Intelligent Adaptive Program Battery Control Technology

In order to extend the off-grid autonomy of the HYBRID under shady trees, heavy rain, and thick clouds, our controllers now integrate an adaptive smart control feature to actively track battery capacity and adjust light output accordingly. Before integrating this feature, selecting a light output percentage on the remote would yield an accurate percentage of max LED brightness. Now with (IAP), the controller actively monitors the battery and regulates the electrical current to the LEDs. The controller makes light output of the selected percentage on the remote relative to battery capacity rather than max LED output. This smart-control feature can increase our off-grid performance by up to 40%.

## 5. Night Owl Mode

Changes as natural light decreases/increases (turns on at dusk); 70% brightness for 0.5 hour, 100% brightness for 3.5 hours, 70% brightness for 1 hour, 50% brightness for 1 hour, 20% brightness for 5 hours (turns off at Dawn).

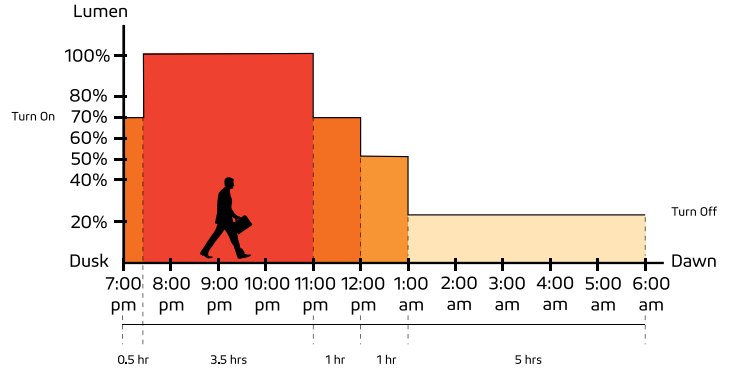

## 6. Early Bird Mode

Changes as natural light decreases/increases with increased brightness near dawn for early risers (turns on at dusk); 70% brightness for 0.5 hour, 100% brightness for 3.5 hours, 70% brightness for 1 hour, 50% brightness for 1 hour, 20% brightness for 4 hours, 100% brightness for 1 hour (turns off at Dawn).

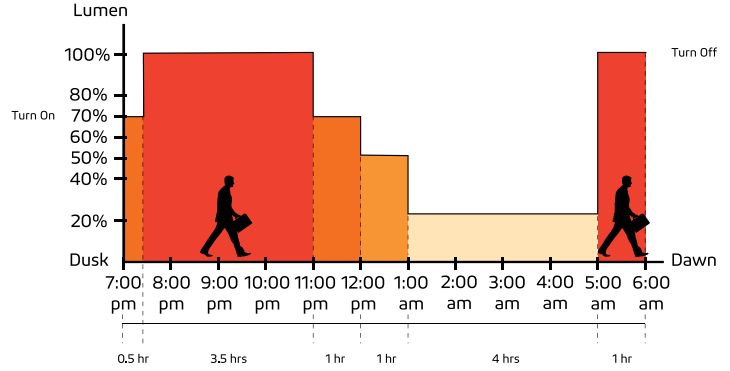

## Important

Dusk and dawn time can vary for different locations and seasons. The sensors in our products will monitor the light levels where it is installed. The time period shown in the chart above is just an example to help you understand the different lighting modes.

### 7. 100% Constant Mode

100% brightness from dusk to dawn.

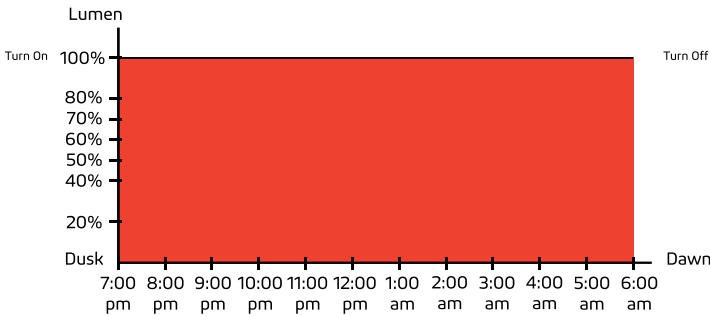

### 8. 70% Constant Mode

70% brightness from dusk to dawn.

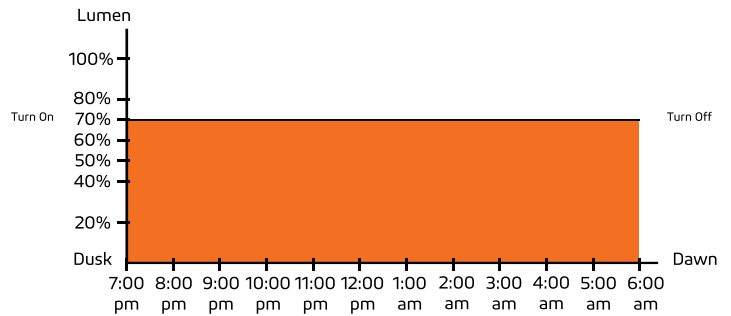

### 9. 40% Constant Mode

40% brightness from dusk to dawn.

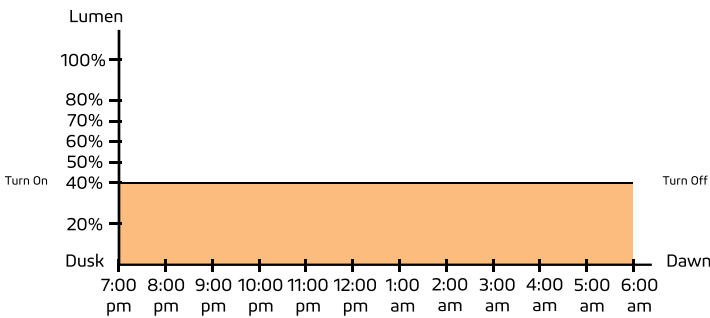

### 10. Timer Mode Disabled

Press this button to turn off Timer Mode; settings revert back to before Timer Mode was last activated.

### 11. Timer Mode 4 Hours

This is an additional mode which can work with any other modes. For example: press this button at any time after you turn on 70% Constant Mode. If the light turns on at 7pm at dusk, it will turn off at 11pm. It will repeat the same schedule hereafter until it is canceled by pressing Timer Mode Disabled.

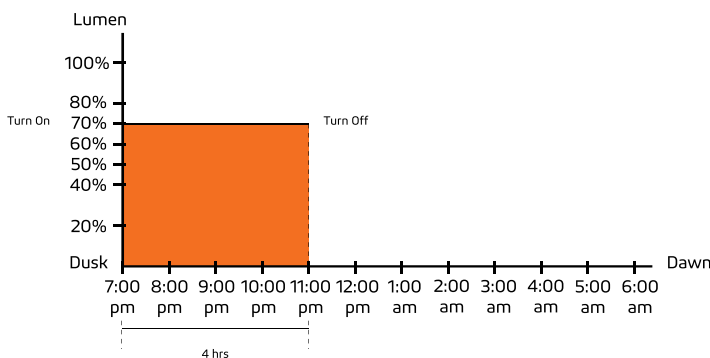

### 12. Time Mode 8 Hours

This is an additional mode which can work with any other modes. For example: press this button at any time after you turn on 70% Constant Mode. If the light turns on at 7pm at dusk, it will turn off at 3am. It will repeat the same schedule hereafter until it is canceled by pressing Timer Mode Disabled.

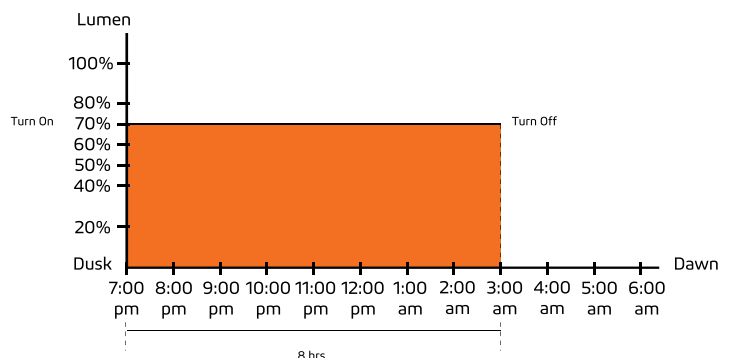

**HYBRID products are covered by a 5 year limited warranty. SOLTECH urban light warrants to the original purchaser that this product is free from defects in materials and workmanship for the period of 5 years from date of purchase. To obtain warranty service please contact your local distributor or sales rep for further instruction.**



---

*SOLTECH LLC reserves the right to update all product data sheets at any time. Consult SOLTECH marketing specialists for publication updates at [hello@soltechlighting.com](mailto:hello@soltechlighting.com)*

*Copyright©2018-2024 SOLTECH LLC,  
All Rights Reserved.*



**SOLTECH Designs  
and Manufactures  
Advanced,  
Solar-Powered  
LED Technology.**