



ORINDA 25W Dual-Heads

CATALOG		COMMENTS
PROJECT		
PREPARED BY		
DATE		

APPLICATIONS

The ORINDA is a complete solar system used for areas such as pathways, parking lots, landscaping, parks, schools, trails, or any remote locations that have no access to conventional power.

The ORINDA fixture is an efficient decorative bell-style fixture and provides great light output. This fixture works best for applications with a mounting height of 15' to 25'.

DESCRIPTION

ORINDA solar light efficiently illuminates outdoor spaces like parking lots, pathways, and parks. This solar light fixture provides 360-degree glare-free, beam-styled lighting. Powered by renewable solar energy, ORINDA is a stand-alone, off-grid pathway light with zero operational costs. ORINDA's elegant design makes it ideal for decorative commercial lighting.

The ORINDA high-powered LED solar lighting system comes complete with solar power assembly, fixture, bracket, and all mounting hardware to attach to a pole. SOLTECH can also provide a pole to meet wind load specifications.

CERTIFICATION DATA



ORDERING INFORMATION

SERIES	WATTAGE	OPTIC TYPE	COLOR TEMPERATURE	MOUNTING OPTIONS	FINISH
STLORN=ORINDA	25D=25W Dual-Heads 9,000 LUMENS	T3=TYPE III	3=3000K 4=4000K	SF=SLIP FITTER	BK=BLACK (RAL 9004) GR=GREEN (RAL 6012)

- - - - -

SPECIFICATION FEATURES



50+ Hours Max Autonomy

- 640 WH battery capacity
- Full self-charging time less than 11 hrs
- Remote control included with one-button mode settings



Greater Energy Production

- 115W Mono Crystalline Solar Panel
- Adjustable panel angle for the fixture allows maximum solar collection and self-cleaning of the solar panel surface



High Brightness, Smart Power Consumption

- Microwave motion sensor and one-key automatic dimming
- Automatically switches to 40% energy-saving mode during low battery capacity
- 180lm/, the highest efficiency in the industry



Longer Life

- Grade A LifePO₄ Battery Pack, 2000+ full charging cycles
- Lumileds 5050 LED chips



Complete Universality

- Acts as a solar flood light
- Grid Free Lighting Systems
- Zero Electric Bills
- No Trenching or Disturbing Surrounding Areas



Low Maintenance Design

- Field-replaceable battery functionality via quick connections
- Marine Grade Aluminum & Stainless Steel Fasteners For Harsh Environments



ORINDA 25W Dual-Heads

CATALOG		COMMENTS
PROJECT		
PREPARED BY		
DATE		

PRODUCT SIZE

ORINDA 25W Dual-Heads

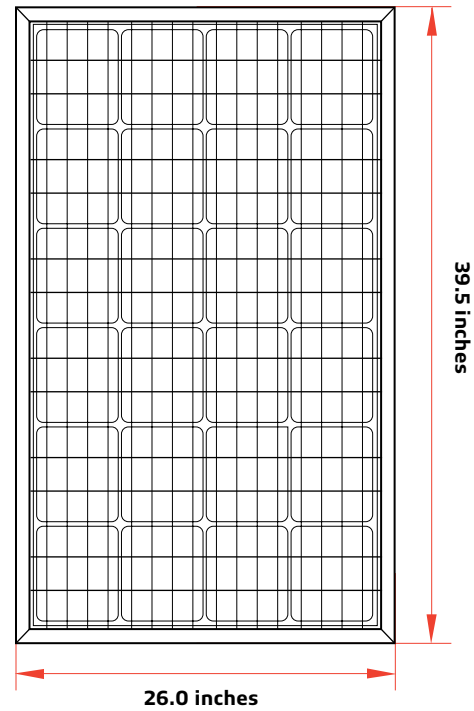
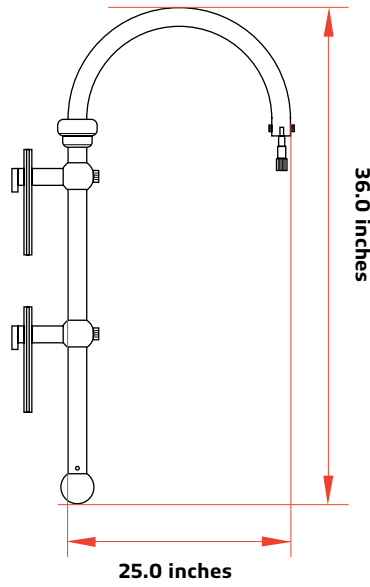
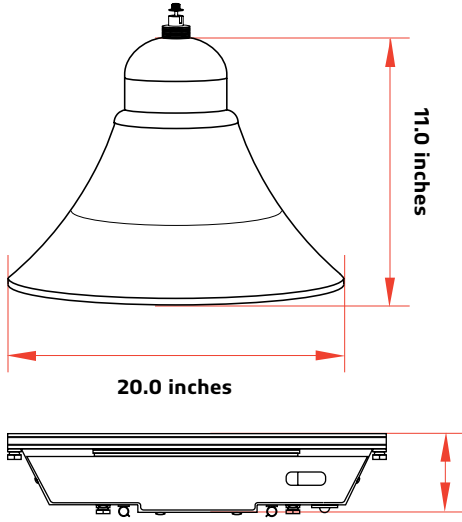

Weight Information

- Battery and Solar Panel: 48lbs
- Solar Lamp: 12lbs/each
- Mounting Bracket: 6lbs/each



ORINDA 25W Dual-Heads

CATALOG		COMMENTS
PROJECT		
PREPARED BY		
DATE		

SOLAR PANEL SLIP FITTER

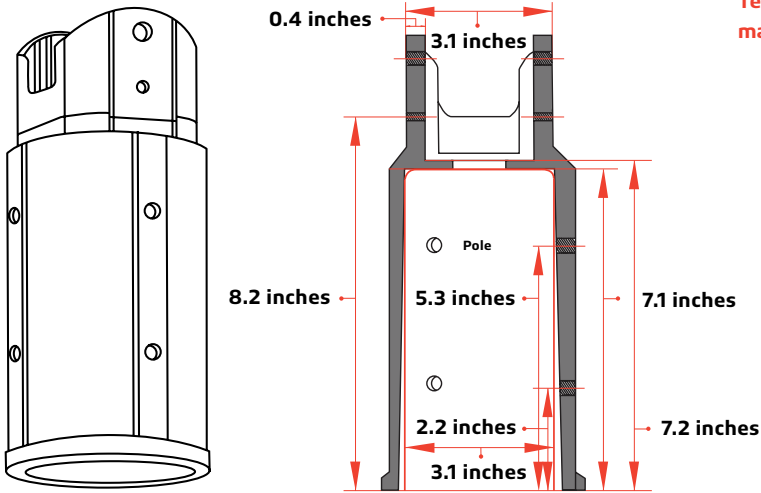

POLE TENON ADAPTER DIAMENTION

Tenon adapter IS NOT included in the package, please contact the pole manufacturer for the details.

Tenon Adapter—Round

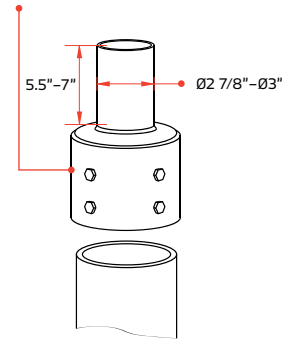



ORINDA 25W Dual-Heads

CATALOG		COMMENTS
PROJECT		
PREPARED BY		
DATE		

IES / BEAM

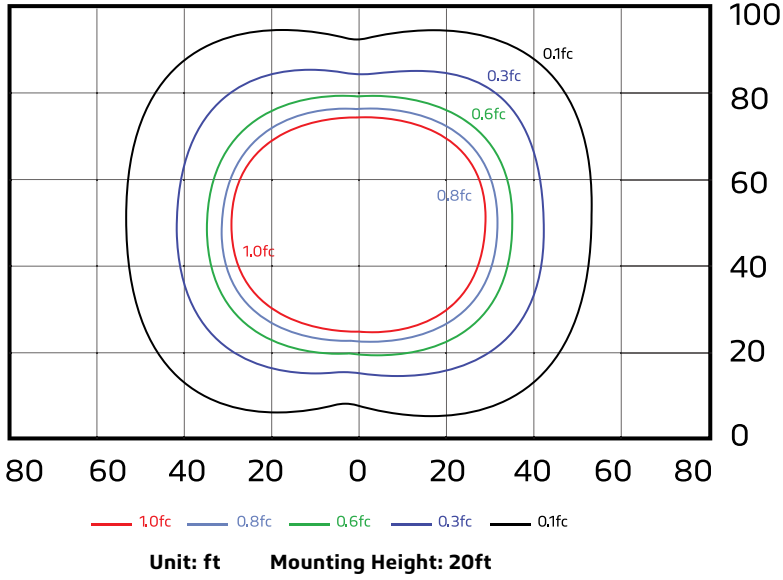

ORINDA 25W Dual-Heads Type III

CATALOG		COMMENTS
PROJECT		
PREPARED BY		
DATE		

SPECIFICATIONS

Specification	ORINDA 25W Dual-Heads
LED Nominal Power	25W
Solar Panel	18V 115W
LiFePO ₄ Battery	640WH 12.8V 50AH
Lumen Output@5000K	4,500 X 2
CRI	> 70
LED Chip	Lumileds 5050 (210lm-CR>70)
EPA@45°	9.5
Waterproof Rate	IP65
Casting	Aluminum
Efficiency@5000K	180 lm/W
* Charging Time	11hrs
Run Time(@Full Power)	12-14hrs
Operation Mode	Remote control and One-key Setting
Installation Height	15 to 25 ft
* Operating Temperature	-20°C/-4°F to 122°F
* Charging Temperature	0°C/32°F to 149°F
Maximum Autonomy	
Motion Sensor Mode	40%-100% 32hrs 20%-80% 55hrs
Time Control Mode	Night Owl 28hrs Early Bird 25hrs
Constant Mode	100% 13hrs 70% 19hrs 40% 34hrs

* The temperature can impact the battery's charging and normal operation. If your place's temperature is under 32°F, we advice you to use the SUNLIKE PRO version to achieve better lighting results.

* The solar charge time data is base on 77 degree F ambient temperature with the panel pointed directly at the solar radiation. The standard radiation value is 1000W/m².

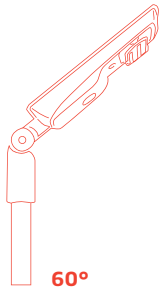

60°



Alaska

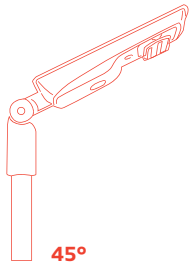

45°

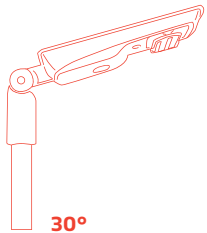
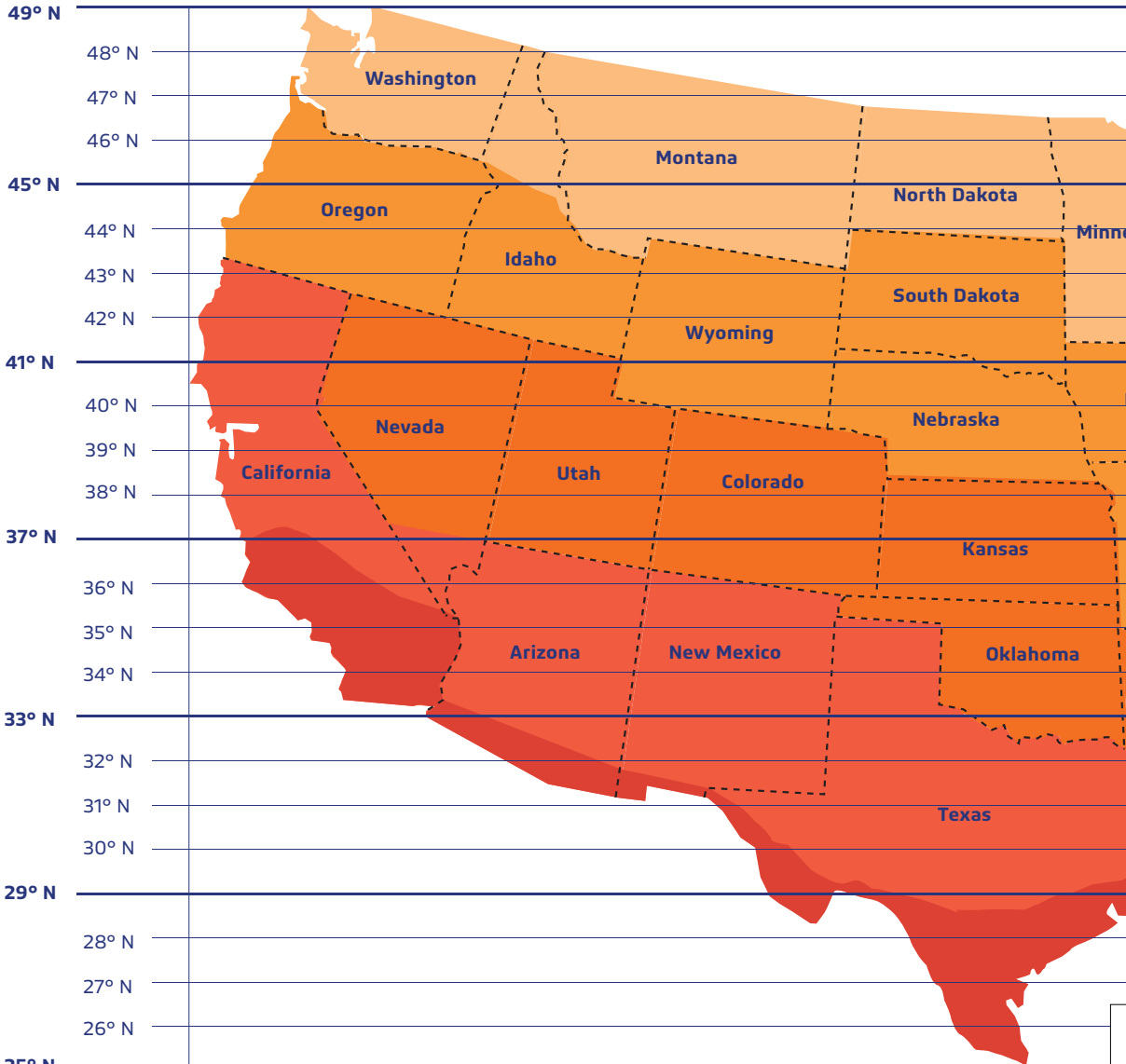

30°

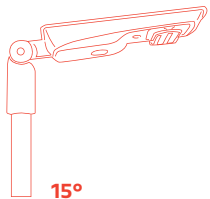

15°



Hawaii

CATALOG		COMMENTS
PROJECT		
PREPARED BY		
DATE		

ORINDA 25W Dual-Heads

The solar charge in a battery pack won't last forever. The off-grid system relies on stored solar energy for autonomy. Angling your solar panels properly can boost the power intake of your solar lighting system. You want to angle your solar panels at a tilt based on the area's latitude.

Tip

You can increase the tilt 15° in the winter or decrease 15° in the summer. In this way you can get the maximum sunlight to recharge the battery

Key



Best Facing Direction of Solar Panel

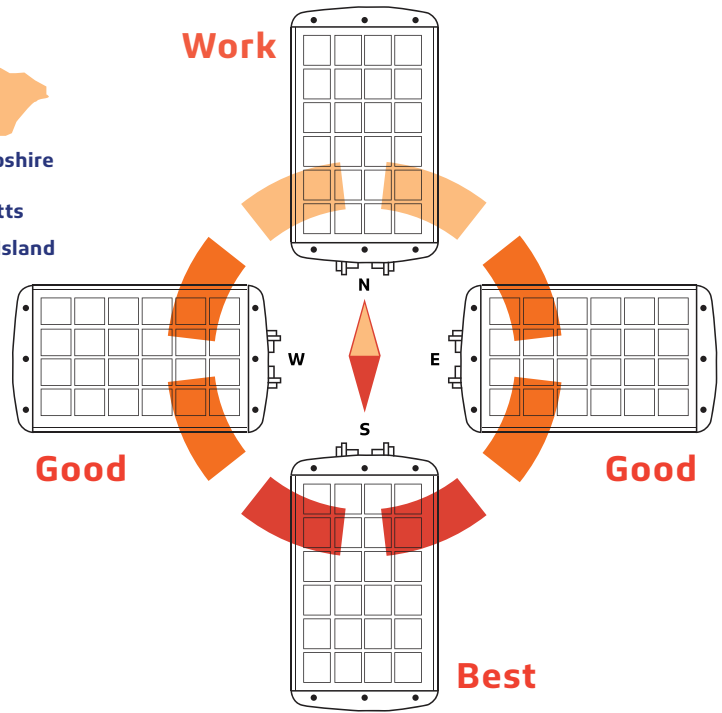

The area will dictate the installation of the fixtures and will sometimes prevent the lights from facing south. But that's okay! Panels facing West & East won't get as much light as Southern facing panels, but will still collect a good amount of sunlight. A North facing panel also works, but it will take longer to charge than any other direction. This would mean that the solar charge will be less optimal if installations are facing North.

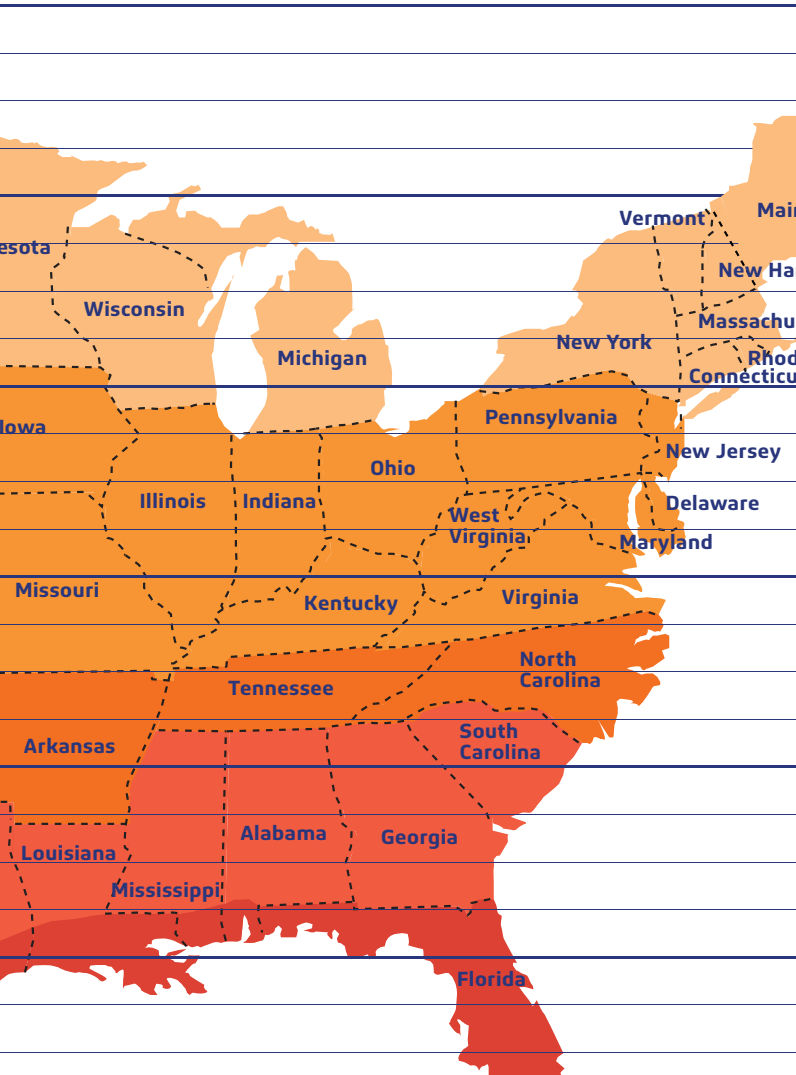

World Wide Panel Angles

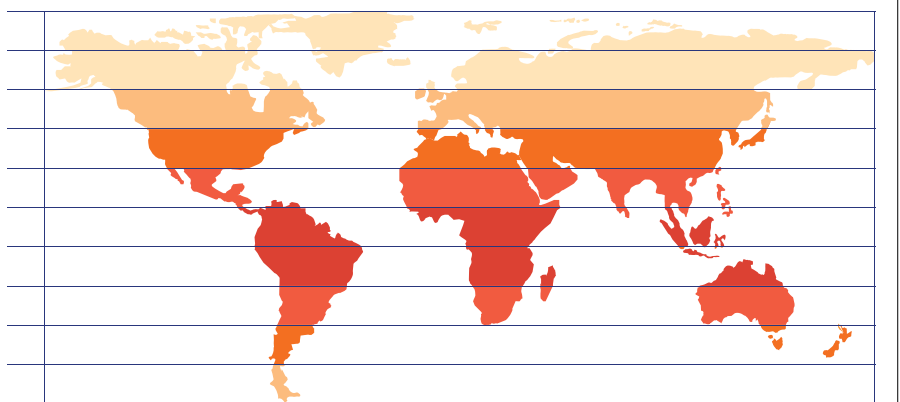
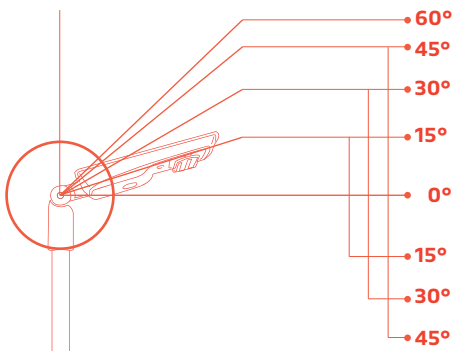

CATALOG		COMMENTS
PROJECT		
PREPARED BY		
DATE		

REMOTE CONTROLS

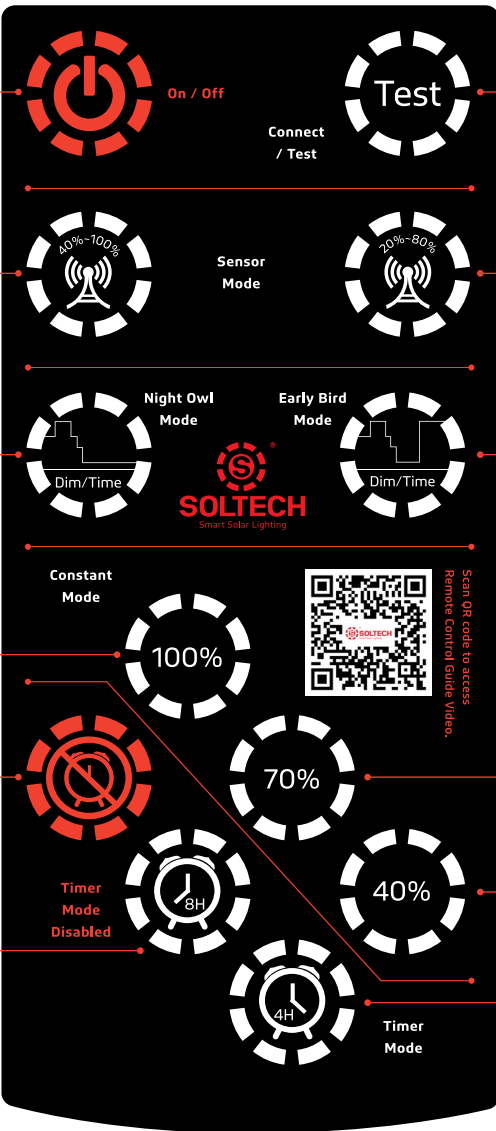

The remote control features the following buttons and functions:

- 1. On/Off**: Power button (On / Off)
- 2. Connect/Test**: Connect / Test button
- 3. 40%-100% Motion Sensor Mode**: Motion sensor mode button (40%-100%)
- 4. 20%-80% Motion Sensor Mode (Default)**: Motion sensor mode button (20%-80%)
- 5. Night Owl Mode**: Night Owl Mode button (Dim/Time)
- 6. Early Bird Mode**: Early Bird Mode button (Dim/Time)
- 7. 100% Constant Mode**: Constant Mode button (100%)
- 8. 70% Constant Mode**: Constant Mode button (70%)
- 9. 40% Constant Mode**: Constant Mode button (40%)
- 10. Timer Mode Disabled**: Timer Mode Disabled button
- 11. Timer Mode 4 Hours**: Timer Mode button (4H)
- 12. Time Mode 8 Hours**: Timer Mode button (8H)

A QR code is located on the remote, with the text: "Scan QR code to access Remote Control Guide Video."

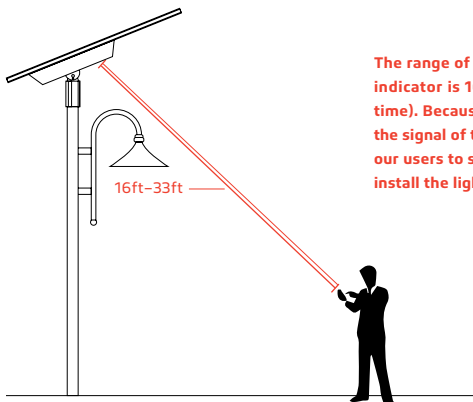

The range of the remote control to the indicator is 16ft (Day time) to 33ft (Night time). Because the sunlight will impact the signal of the remote control, we suggest our users to setup the mode before they install the light.

1. On/Off

When off is selected, the light will stop working. The solar panel will not charge the battery and the battery will not supply electricity to the light.

2. Connect/Test

Remote control device can be connected with any lighting fixture, one at a time. To connect, press the button once. It also functions as a test button. To test, press the "Test" button once, the red light will indicate the fixture is charging, green light indicates that the fixture is operating. Testing lasts for 10 seconds, and then it goes back to the mode previously in use.

ORINDA 25W Dual-Heads

REMOTE CONTROLS

3. 40%-100% Motion Sensor Mode

Constant 40% brightness (turns on at dusk, turns off at dawn); 100% brightness turns on for 2 minutes when motion is detected.

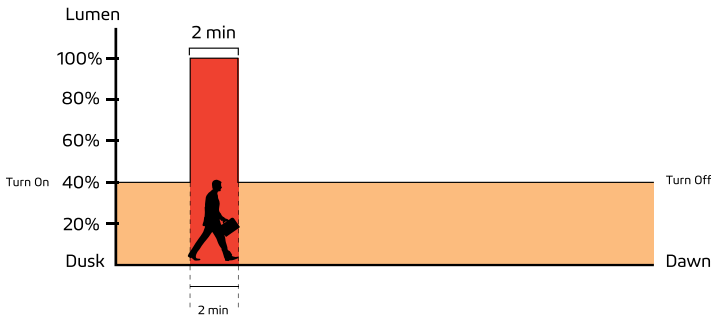

4. 20%-80% Motion Sensor Mode (Default)

Constant 20% brightness (turns on at dusk, turns off at dawn); 80% brightness turns on for 2 minutes when motion is detected.

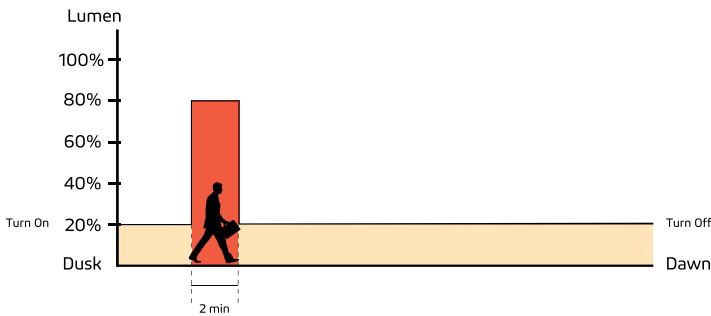

(IAP) Intelligent Adaptive Program Battery Control Technology

In order to extend the off-grid autonomy of the ORINDA under shady trees, heavy rain, and thick clouds, our controllers now integrate an adaptive smart control feature to actively track battery capacity and adjust light output accordingly. Before integrating this feature, selecting a light output percentage on the remote would yield an accurate percentage of max LED brightness. Now with (IAP), the controller actively monitors the battery and regulates the electrical current to the LEDs. The controller makes light output of the selected percentage on the remote relative to battery capacity rather than max LED output. This smart-control feature can increase our off-grid performance by up to 40%.

CATALOG		COMMENTS
PROJECT		
PREPARED BY		
DATE		

5. Night Owl Mode

Changes as natural light decreases/increases (turns on at dusk); 70% brightness for 0.5 hour, 100% brightness for 3.5 hours, 70% brightness for 1 hour, 50% brightness for 1 hour, 20% brightness for 5 hours (turns off at Dawn).

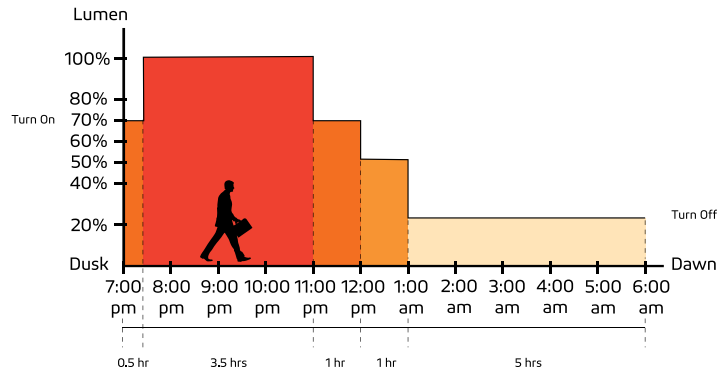

6. Early Bird Mode

Changes as natural light decreases/increases with increased brightness near dawn for early risers (turns on at dusk); 70% brightness for 0.5 hour, 100% brightness for 3.5 hours, 70% brightness for 1 hour, 50% brightness for 1 hour, 20% brightness for 4 hours, 100% brightness for 1 hour (turns off at Dawn).

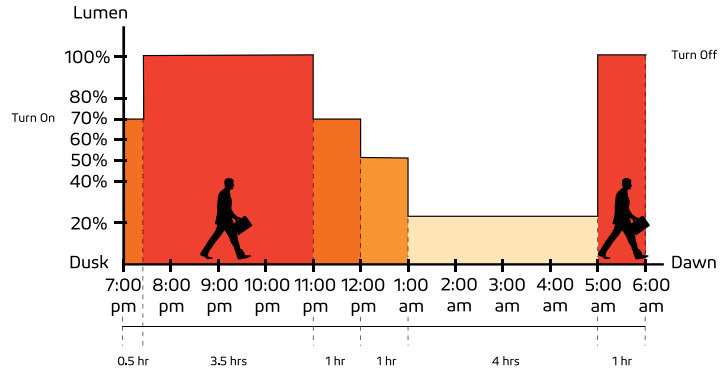

Important

Dusk and dawn time may be different in other locations and seasons. The sensors of our products will follow the light patterns of where it is installed. The time period shown in the chart above is just an example to help you understand the different lighting modes only.



ORINDA 25W Dual-Heads

CATALOG		COMMENTS
PROJECT		
PREPARED BY		
DATE		

REMOTE CONTROLS

7. 100% Constant Mode

100% brightness from dusk to dawn.

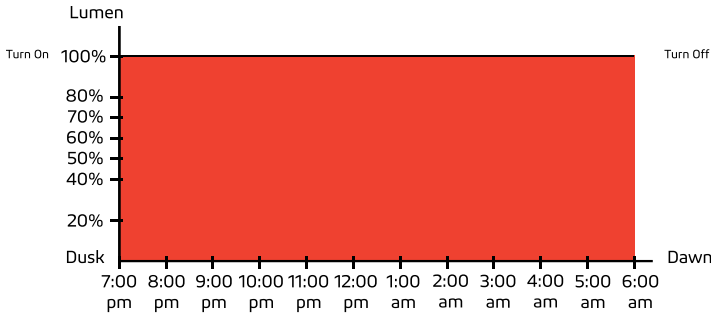

8. 70% Constant Mode

70% brightness from dusk to dawn.

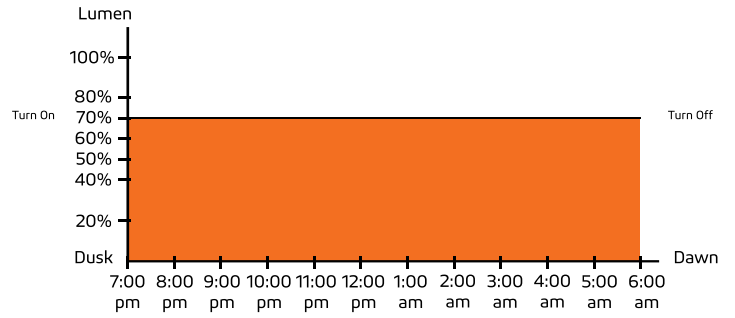

9. 40% Constant Mode

40% brightness from dusk to dawn.

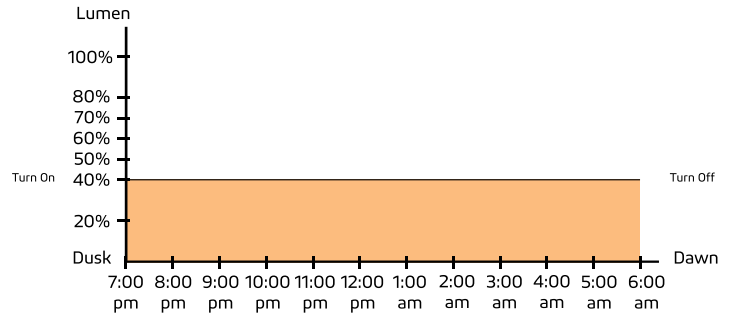

10. Timer Mode Disabled

Press this button to turn off Timer Mode; settings revert back to before Timer Mode was last activated.



ORINDA 25W Dual-Heads

CATALOG		COMMENTS
PROJECT		
PREPARED BY		
DATE		

REMOTE CONTROLS

11. Timer Mode 4 Hours

This is an additional mode which can work with any other modes. For example: press this button at any time after you turn on 70% Constant Mode. If the light turns on at 7pm at dusk, it will turn off at 11pm. It will repeat the same schedule hereafter until it is canceled by pressing Timer Mode Disabled.

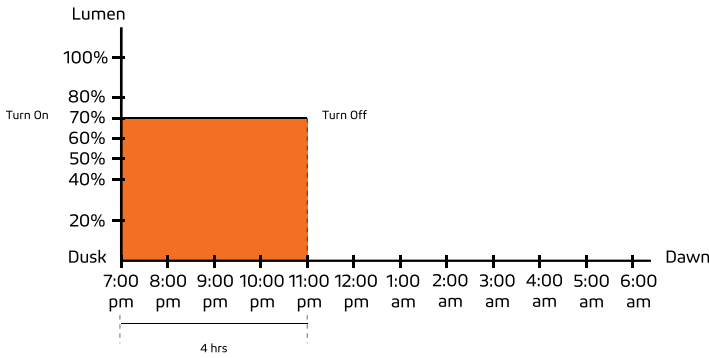

12. Time Mode 8 Hours

This is an additional mode which can work with any other modes. For example: press this button at any time after you turn on 70% Constant Mode. If the light turns on at 7pm at dusk, it will turn off at 3am. It will repeat the same schedule hereafter until it is canceled by pressing Timer Mode Disabled.

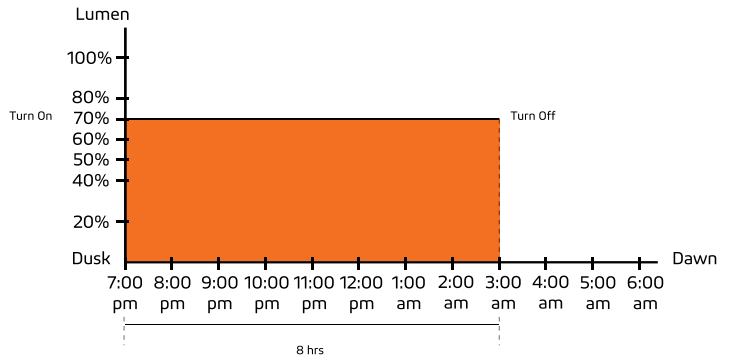

Important

Dusk and dawn time can vary for different locations and seasons. The sensors in our products will monitor the light levels where it is installed. The time period shown in the chart above is just an example to help you understand the different lighting modes.



ORINDA 25W Dual-Heads

CATALOG		COMMENTS
PROJECT		
PREPARED BY		
DATE		

WARRANTY

ORINDA products are covered by a 5 year limited warranty. SOLTECH urban light warrants to the original purchaser that this product is free from defects in materials and workmanship for the period of 5 years from date of purchase. To obtain warranty service please contact your local distributor or sales rep for further instruction.



1460 Park Avenue.
Emeryville, CA 94608 USA

www.soltechlighting.com

SOLTECH LLC reserves the right to update all product data sheets at any time. Consult SOLTECH marketing specialists for publication updates at hello@soltechlighting.com

Copyright©2018–2024 SOLTECH LLC,
All Rights Reserved.