



SOLPAD 5W 10W

APPLICATIONS

This compact, integrated flood light pad is ideal to create brightly-lit, outdoor applications for residential garages, parking lots, schools, hotels and outdoor walk ways, that demand long service life and low maintenance. Three smart lighting mode options address all kinds of applications and weather.

DESCRIPTION

The SOLPAD features an integrated design that makes this one of the easiest lights to install and can mount to many different wall surfaces. SOLPAD also eliminates trenching, cabling, and electricity costs. With its advanced sensors, it can automatically turn off when it is daylight and turn on at dusk. The light can be programmed using buttons on the fixture, or using a simple handheld remote. Using the motion sensor function, the light can detect motion and will turn on automatically when it senses movement. With only six hours of sunlight, the fixture can operate for three to four days.

ORDERING INFORMATION

SERIES	WATTAGE	COLOR TEMPERATURE	MOUNTING OPTIONS	FINISH
STL-SFL=SOLPAD	5=5W 500 Lumens 10=10W 1,000 Lumens	4=4000K 5=5000K	WM=Wall Mount LP=LAMP-POST MOUNT	BK=BLACK

- - - -

SPECIFICATION FEATURES



Generates More Solar Energy and Stores More Energy

- Solar panel bracket is 360° adjustable and the light module is 135° adjustable. The Adjustable solar panel angle enables maximizing sunlight collected and allows snow to slide off.
- Large battery capacity of 7200mAh enables long run times.



Longer Life

- The latest advanced Li-ion battery lasts 2000+ charging cycles
- 3 operating modes that are programmable via remote control or controls on the fixture
- IP65 rated protection from water, dirt, and dust.



Installation

- Wall-mounting and post-mounting accessories available.



Integrated Design

- The easiest way to bring lighting to any outdoor application.
- Photo and motion sensors, wide angle 180° detection, high sensitivity
- Wall-mounting and post-mounting accessories available.

CATALOG	PROJECT	COMMENTS

CERTIFICATION DATA





SOLPAD 5W 10W

CATALOG		COMMENTS
PROJECT		
PREPARED BY		
DATE		

PRODUCT SIZE
SOLPAD 5W

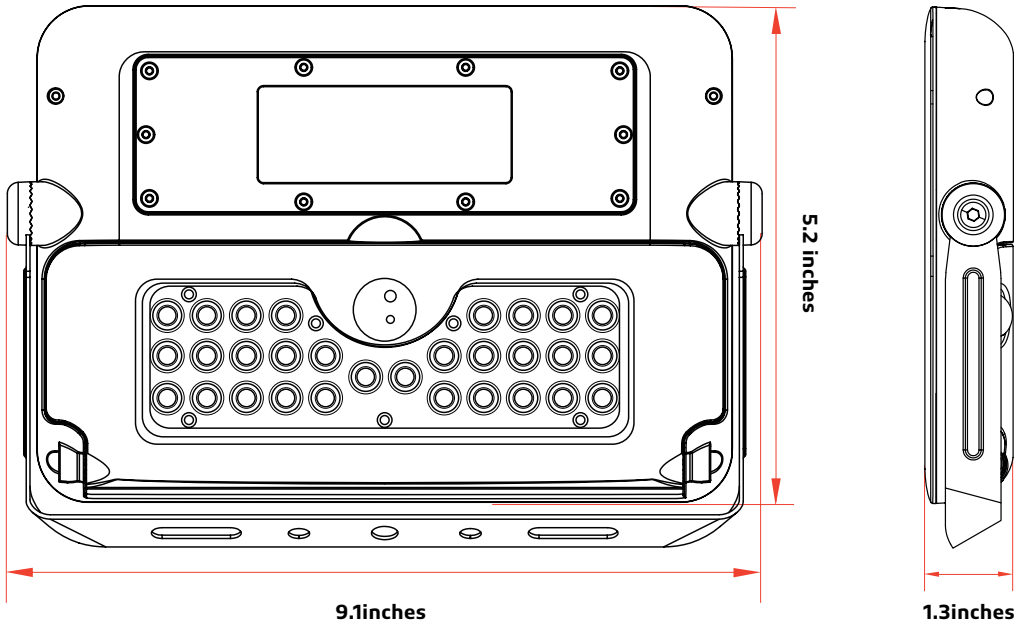

SOLPAD 10W

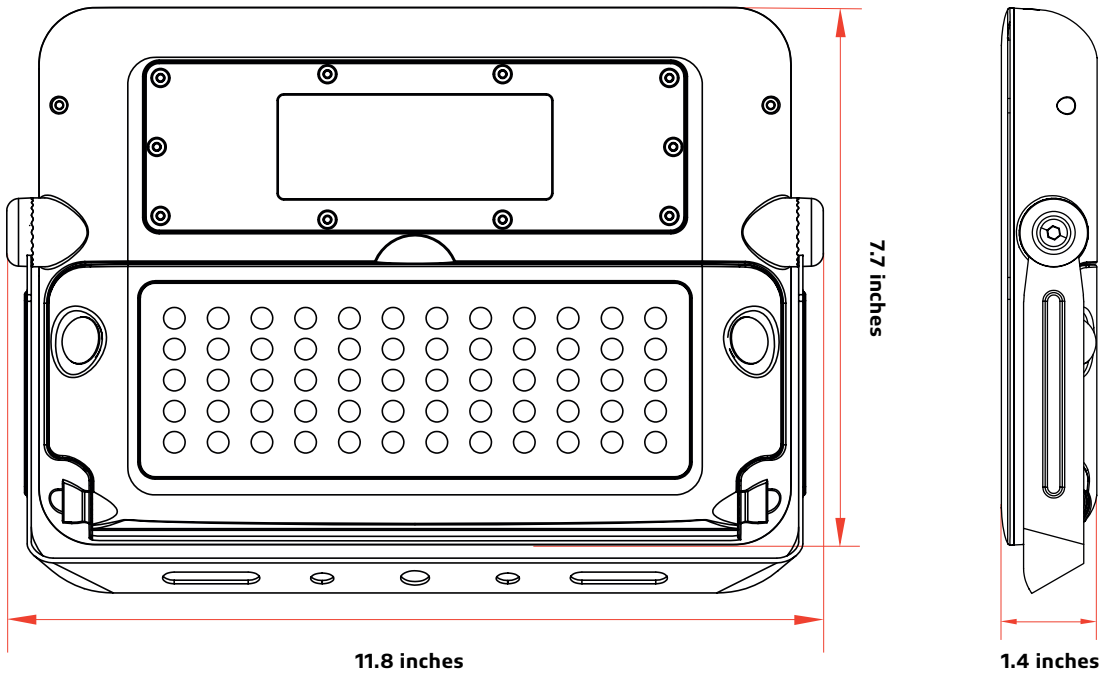



SOLPAD 5W 10W

CATALOG		COMMENTS
PROJECT		
PREPARED BY		
DATE		

SPECIFICATIONS

LED Nominal Power	5W	10W
Solar Panel	Mono-Crystalline 5.5V 3.2W	Mono-Crystalline 5.5V 6W
Lithium Ion Battery	3.7V	3.7V
CCT	4,000K & 5,000K	4,000K & 5,000K
Lumen Output@4000K	500	1,000
CRI	> 70	> 70
Product Size	9.1 X 5.2 X 1.3 Inches	10.2 X 12.2 X 5.1 Inches
Beam Angle	90°	90°
Waterproof Rate	IP65	IP65
Casting	PC & Aluminum	PC & Aluminum
Efficiency@4000K	100 lm/W	100 lm/W
* Charging Time	7hrs (1000W/m ²)	7hrs (1000W/m ²)
Run Time (@Full Power)	2-3 Days	2-3 Days
Operation Mode	3 Operating Modes	3 Operating Modes
PIR Sensor Angle / Distance	120° / 16.7 ft	180° / 16-26 ft
* Operating Temperature	-20.5°C/-5°F to 113°F	-20.5°C/-5°F to 113°F
* Charging Temperature	0°C/32°F to 149°F	0°C/32°F to 149°F

* The temperature can impact the battery's charging and normal operation.

* The solar charge time data is base on 77 degree F ambient temperature with the panel pointed directly at the solar radiation. The standard radiation value is 1000W/m².

SOLPAD 5W 10W

CATALOG		COMMENTS
PROJECT		
PREPARED BY		
DATE		

IES / BEAM

SOLPAD 5W [MOUNTING HEIGHT: 10FT]

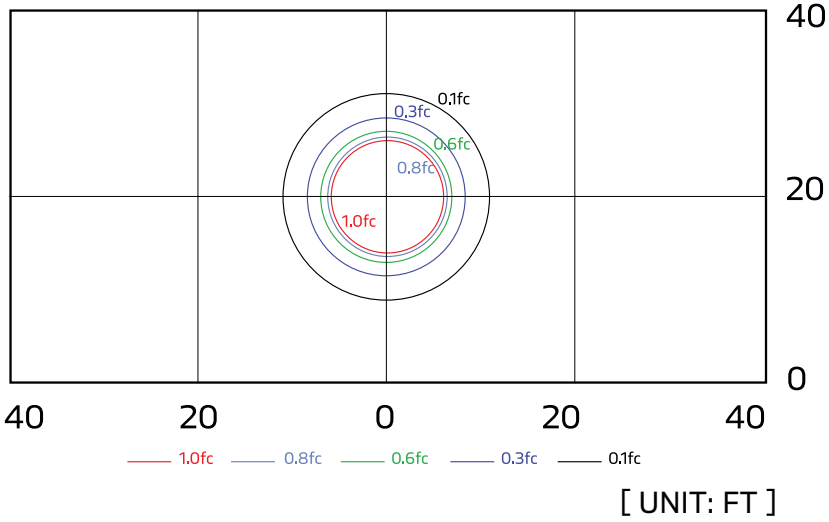

SOLPAD 10W [MOUNTING HEIGHT: 10FT]

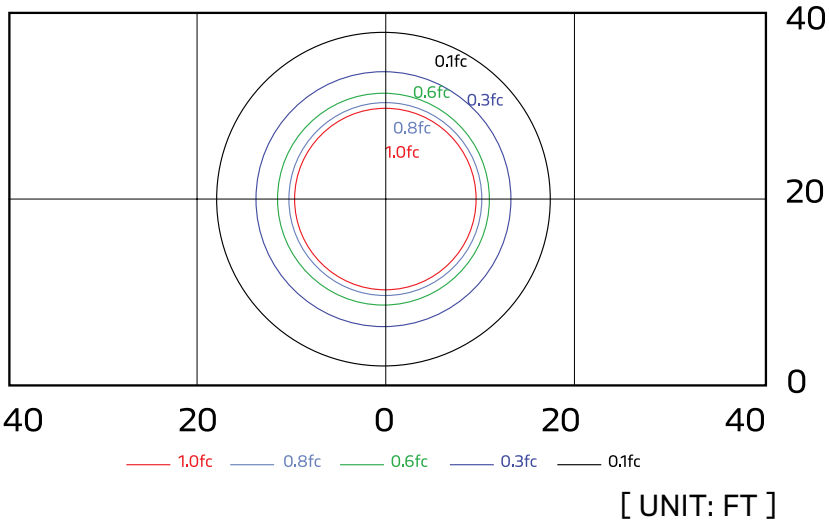

**INSTALLATION 5W
WALL MOUNT**

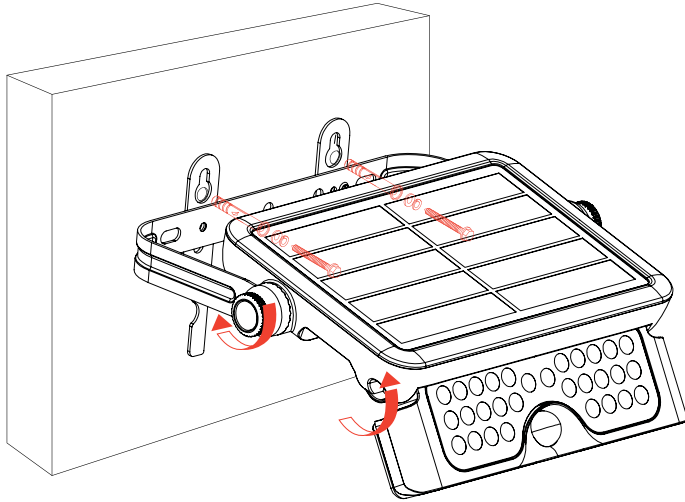

1. Use the Allen Wrench to loosen the bracket. Adjust it to the appropriate angle and tighten screws.
2. Use the Allen Wrench to loosen the light module. Pull it out and adjust it to your desired lighting angle, then tighten screws.
3. Mount the light onto the wall.

CATALOG		COMMENTS
PROJECT		
PREPARED BY		
DATE		

STAND ON FLAT SURFACE

01.

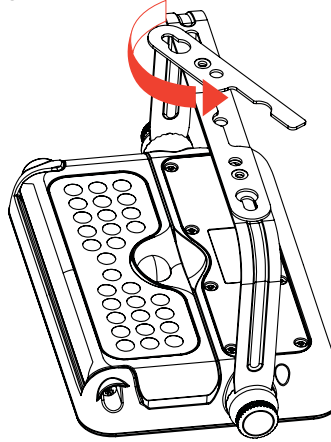

02.

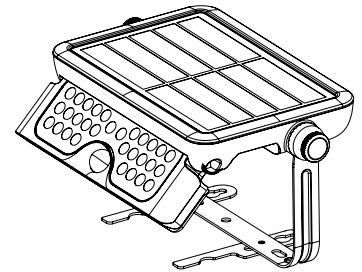

1. Prepare lamp, accessories, and tools.
2. Use the allen wrench to loosen the bracket.

CATALOG		COMMENTS
PROJECT		
PREPARED BY		
DATE		

INSTALLATION 10W

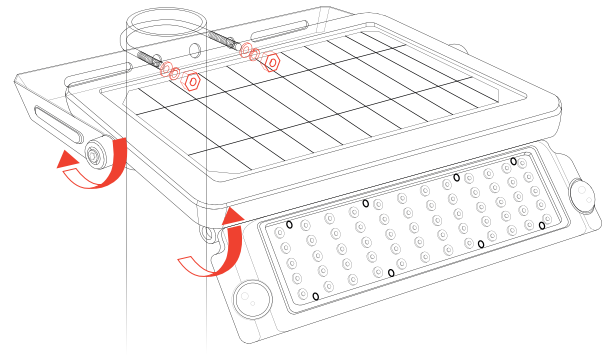
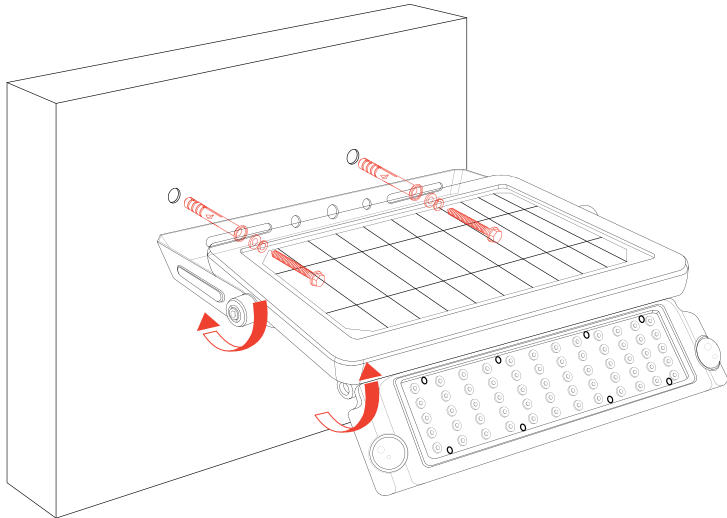

1. Use the Allen Wrench to loosen the bracket. Adjust it to the appropriate angle and tighten screws.
2. Use the Allen Wrench to loosen the light module. Pull it out and adjust it to your desired lighting angle, then tighten screws.
3. Mount the light onto the wall.

Works With Round & Square Poles

1. Round Pole Mount
Diameter of 1.6–2.4 inches
2. Square Pole Mount
Side length of 1.2–1.6 inches

OPERATING MODES

1. Automatically turns on at dusk and remains at 20% brightness
2. Automatically turns on to full brightness (1000 lm) when motion is detected within a range of ≤ 26 ft and then reduces to 3% brightness in 20 seconds of no motion.
3. Automatically turns on to full brightness (1000 lm) when motion is detection within a range of ≤ 26 ft and then turns off after 30 seconds of no motion.

REMOTE CONTROLS

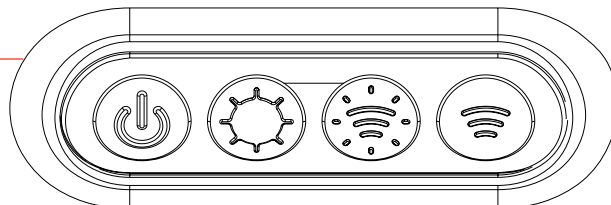
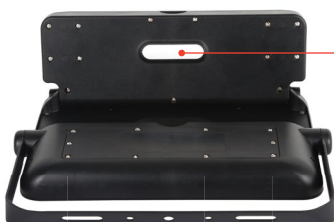

Please press any button to specific operating mode, 6 hours of sunlight can provide operation for 3–4 nights.

CATALOG		COMMENTS
PROJECT		
PREPARED BY		
DATE		

REMOTE CONTROLS



1. On / Off



2. Constant Lighting Mode

Automatically turns on at dusk and remains 20% brightness.

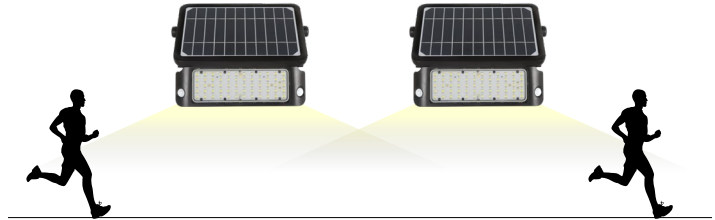

3. Full Bright & Dim

Automatically turns on to full brightness (1080lm) when motion is detected in the range $\leq 26\text{ft}$ and then turns to 3% brightness in 20 seconds of no motion.



4. Full Bright & Off

Automatically turns on to full brightness (1080lm) when motion is detected in the range $\leq 26\text{ft}$ and then turns off in 30 seconds of no motion.





SOLPAD 5W 10W

CATALOG		COMMENTS
PROJECT		
PREPARED BY		
DATE		

WARRANTY

SOLPAD products are covered by a 3 year limited warranty. SOLTECH urban light warrants to the original purchaser that this product is free from defects in materials and workmanship for the period of 3 years from date of purchase. To obtain warranty service please contact your local distributor or sales rep for further instruction.



1460 Park Avenue.
Emeryville, CA 94608 USA

www.soltechlighting.com

SOLTECH LLC reserves the right to update all product data sheets at any time. Consult SOLTECH marketing specialists for publication updates at hello@soltechlighting.com

Copyright©2022-2023 SOLTECH LLC,
All Rights Reserved.